LOW VOLTAGE AC DRIVES

ABB industrial drives

ACS880, multidrives

1.5 to 6000 kW



—

**Uncompromised productivity.
ACS880 series.**

ABB industrial drives

ACS880, multidrives

04 – 19	THE ALL-COMPATIBLE ACS880 DRIVE SERIES		
	06 – 07	SIMPLIFY YOUR WORLD WITHOUT LIMITING YOUR POSSIBILITIES	
	08	EASY TO USE	
	10 – 11	ENGINEERED-TO-ORDER FOR SIMPLIFIED INSTALLATION	
	12	FIELDBUS AND INDUSTRIAL ETHERNET SOLUTIONS	
	13	MINIMIZED DOWNTIME	
	14	PROTECT YOUR PEOPLE, MACHINERY, AND PROCESSES WITH INTEGRATED DRIVE SAFETY WITH INTEGRATED DRIVE SAFETY	
	15	GLOBAL COMPATIBILITY WITH VARIOUS DEMANDS	
	16	PREMIUM CONTROL AND PROGRAMMABILITY	
	18 – 19	APPLICATION- AND INDUSTRY-SPECIFIC SOLUTIONS	
20	TECHNICAL DATA		
21	HOW TO SELECT A DRIVE		
22 – 25	ACS880 MULTIDRIVES		
26 – 27	ACS880 LIQUID-COOLED MULTIDRIVES		
28 – 41	RATINGS, TYPES AND VOLTAGES		
42 – 45	DIMENSIONS		
46 – 47	STANDARD INTERFACE AND EXTENSIONS FOR PLUG-IN CONNECTIVITY		
48 – 72	OPTIONS		
	48	CONTROL PANEL OPTIONS	
	50	COMMUNICATION AND CONNECTIVITY	
	51	CONNECTIVITY TO AUTOMATION SYSTEMS	
	52	PROFINET S2 SYSTEM REDUNDANCY FOR ABB DRIVES	
	53	FEEDBACK INTERFACE AND DDCS COMMUNICATION OPTIONS	
	54 – 55	ABB ABILITY™ DIGITAL POWERTRAIN	
	56 – 57	COMMISSIONING, PROGRAMMING AND CUSTOMIZATION TOOLS	
	58 – 59	SAFETY OPTIONS	
	60 – 61	EMC – ELECTROMAGNETIC COMPATIBILITY	
	62 – 63	FOR POTENTIALLY EXPLOSIVE ATMOSPHERE	
	64 – 65	SINE FILTERS	
	66 – 70	BRAKE OPTIONS	
	71 – 72	DU/DT FILTERS	
73	ABB AUTOMATION PRODUCTS		
74 – 75	CHOOSE THE RIGHT MOTOR FOR YOUR APPLICATION		
76 – 77	ABB MOTION SERVICES		
78	ABB ABILITY™ MOBILE CONNECT FOR DRIVES		
79 – 86	SUMMARY OF FEATURES AND OPTIONS		
			ACS880 DRIVE SERIES 04 – 19
			TECHNICAL DATA 20
			HOW TO SELECT A DRIVE 21
			ACS880 MULTIDRIVES 22 – 25
			ACS880 LIQUID-COOLED MULTIDRIVES 26 – 27
			RATINGS, TYPES AND VOLTAGES 28 – 41
			DIMENSIONS 42 – 45
			STANDARD INTERFACE AND EXTENSIONS 46 – 47
			OPTIONS 48 – 72
			ABB AUTOMATION PRODUCTS 73
			MOTORS 74 – 75
			ABB MOTION SERVICES 76 – 77
			ABB ABILITY™ MOBILE CONNECT FOR DRIVES 78
			SUMMARY OF FEATURES AND OPTIONS 79 – 86

The all-compatible ACS880 series

Uncompromized productivity

The ACS880 is an all-compatible ABB industrial drive, offered in a range of wall-mounted drives, drive modules and cabinet-built drives.

ABB's all-compatible drives are designed to provide customers across industries and applications with unprecedented levels of compatibility and flexibility. Our cabinet-built ACS880 multidrives are customized to meet the particular needs of specific industries, such as metals, pulp and paper, oil and gas, mining, harbours, offshore, marine, automotive and power plants. They can control a wide range of applications, including paper machines, winders, rolling mills, processing lines, roller tables, cranes, test benches and drilling.

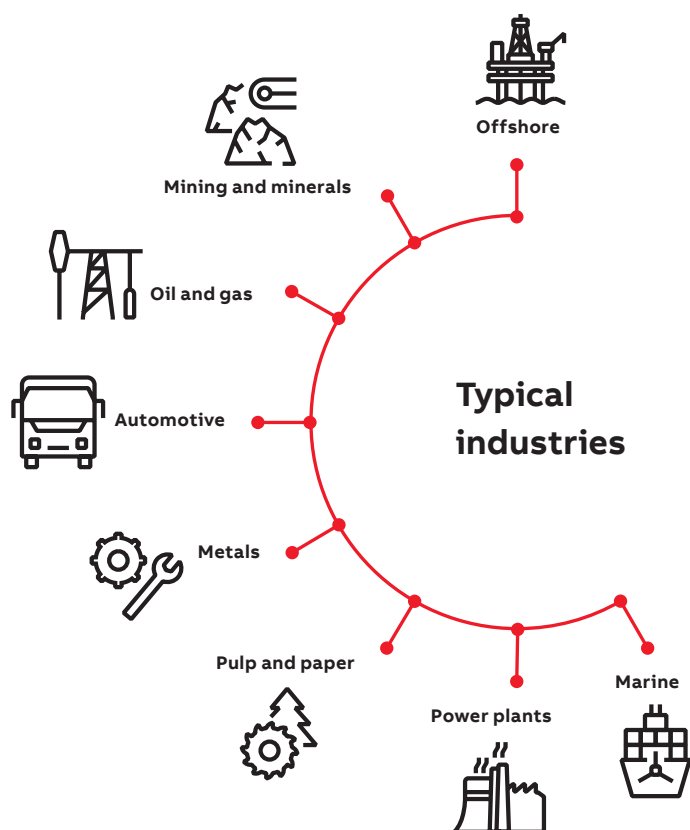

High quality

Reliability and consistent high quality

ACS880 drives are designed for customers who value high quality and robustness in their applications. They have features such as coated boards, making the ACS880 suitable for harsh conditions. Additionally, every ACS880 drive is factory-tested at full load to ensure maximum reliability. The tests include performance and all protective functions.

High performance, safety and configurability

The ACS880 offers the highest level of performance. The drives are equipped with ABB's signature direct torque control (DTC), which provides precise speed and torque control for all applications and supports virtually any type of motor.

Extensive ACS880 offering includes wall-mounted drives, drive modules and cabinet-built drives, as well as low harmonic and regenerative variants.

The ACS880 has all the essential features built-in reducing the time required for engineering, installation and commissioning. A wide range of options are also available to optimize the drive for different requirements, including certified, integrated safety features.



ABB

Simplify your world without limiting your possibilities

Engineered-to-order to meet customers' needs, the ACS880 multidrives can meet technical challenges through a wide selection of options that are all mountable within the cabinet.

Easy to use

- All-compatible drives share the same easy-to-use user interface
- Multilingual control panel with clear display
- Graphical PC tools for engineering, commissioning and maintenance

See page 08



Up to IP54

Engineered-to-order for simplified installation

- All the essential features built-in
- Flexible product configurations engineered-to-order
- Wide selection of options and variants
- Compact design
- Enclosure classes for different environments
- Extensive selection of support material and tools for engineering

See page 10



Fieldbus and Industrial Ethernet solutions

- Communication with all major automation networks
- Remote monitoring
- Integration tools for various PLCs

See page 12



Nine-year maintenance interval

Minimized downtime

- Robust, long lifetime design for maximum reliability
- Coated circuit boards for harsh conditions
- Removable memory unit
- Each drive factory-tested at full load
- Nine-year maintenance interval
- Worldwide service and support
- Advanced features for analyzing and resolving issues

See page 13

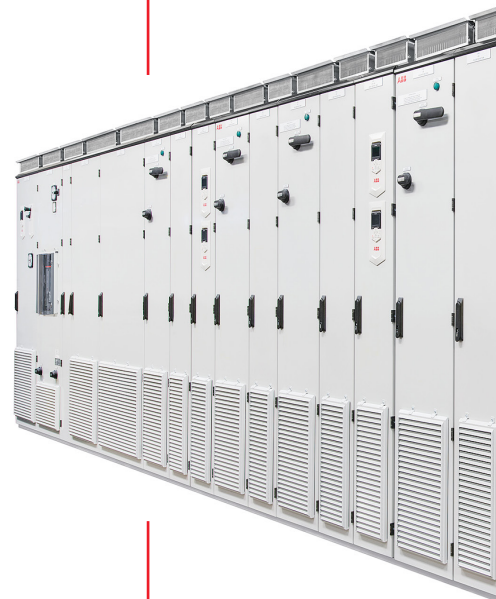

A single supply and DC bus arrangement with multiple inverters reduce line power, cabinet size and investment costs.



Protect your people, machinery, and processes with integrated drive safety

- Safe Torque Off built-in as standard
- Optional safety modules for extended safety functions
- Encoderless safe speed detection
- Highest level of machinery safety, SIL 3 / PL e
- TÜV certified

See page 14



Global compatibility with various demands

- Global product approvals, e.g. CE, UL, cUL, CSA, marine certifications, ATEX
- Support for various motor types
- Low harmonic content
- Possibility for regeneration

See page 15

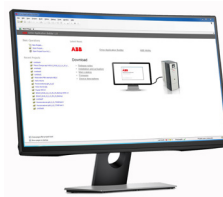

Premium control and programmability

- Direct torque control (DTC) for precise control
- Speed, torque and position control as well as synchronizing
- Adaptive programming as standard
- Drive-based PLC programmability (IEC 61131-3) for fully customized solutions

See page 16

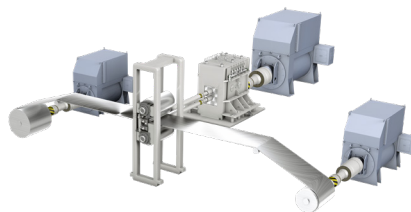

Application- and industry specific solutions

- Ready-made optimized solutions for various applications and industries

See pages 18 - 19

Easy to use

All-compatible user interface saves commissioning and learning time

The ACS880 is part of ABB's all-compatible drives portfolio. Other drives in this portfolio are the ACS380, ACS480 and ACS580.

ABB has a wide range of user interface options, which are intuitive and easy to use and provide a superior experience compared to traditional tools.

The drives also share the same communication options, simplifying the use of drives and spare parts handling.

Simplicity at your fingertips as standard

As the standard, the ACS880 drive has a control panel with built-in Bluetooth interface, which enables wireless connection with the ABB Drivetune mobile app and with the entry-level Drive Composer PC tool for startup, commissioning, maintenance, and remote support. Control panel has built-in USB port, which enables PC connection using the Drive Composer software for comprehensive commissioning and maintenance.

Drive Composer is designed for the daily operation of the ACS880 drives. It provides extensive drive monitoring capabilities and quick access to drive settings, as well as features like a graphical interface for configuring safety functions, visual control diagrams, and direct links to user manuals.





Engineered-to-order for simplified installation

Compact tailor made design

ACS880 Multidrives offer a wide selection of pre-defined options, which include the typical requirements of different industries.

Our ACS880 Multidrives are always engineered-to-order products. This ensures that the customer's and application's demands are taken as basis of our design and even complex requirements can be included to create a unique solution. Our dedicated team takes care of your needs to ensure the maximum performance, uptime and quality in daily processes.

All ACS880 drives have a choke for harmonic filtering, a Modbus RTU fieldbus interface, and Safe Torque Off functionality as standard. Other built-in features, standard or optional, include EMC filters, brake options, low harmonic and regenerative functionality and various I/O extensions, communication protocol adapters, and functional safety modules. To further simplify the installation, ACS880 multidrives have fast connectors for motor cables.

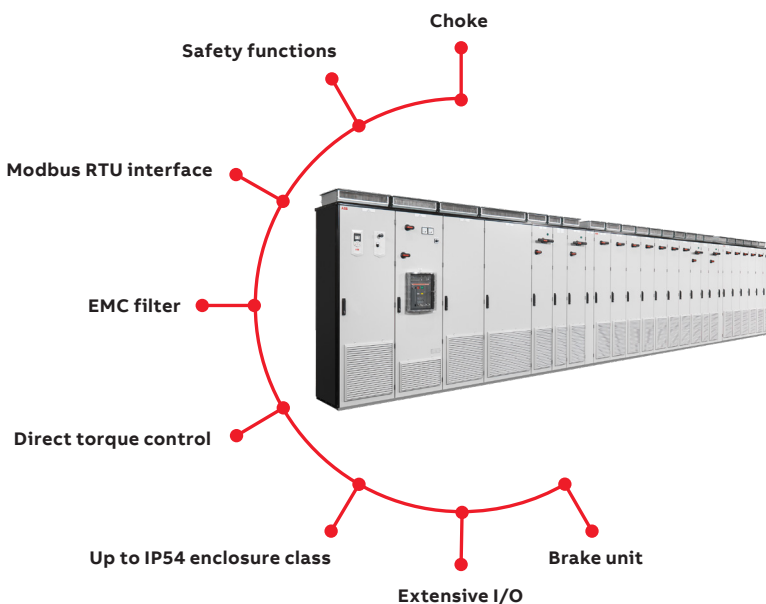

Multidrive design is extremely compact:

- High packing density with 16 inverter units up to frame size R2i can be installed into one cabinet
- Reliable diode bridge with high power density
- Highly efficient thermal handling as heat loss of each inverter unit is guided to the back of the cabinet. All cabinets are their own compartments.

Enclosures for different environments

ACS880 offering includes complete and compact solutions for dusty and wet environments with up to IP54 enclosure class.

All essential features built-in

Engineering support

ABB provides an extensive selection of support material and tools to help in engineering, such as:

- Dimensioning tools, e.g. DriveSize
- Safety circuit design tools
- Configuration tool
- Electrical drawings
- Application guides
- User manuals

These tools and support from our experts ensure that the drive system can be set up easily and reliably.

DriveSize dimensioning tool for selecting the optimal drive

DriveSize is designed to help select the optimal drive, motor and transformer for the application. Based on data supplied by the user, the tool calculates and suggests which drive and motors to use.

DriveSize is a free software and can be used either online or downloaded for PC from <https://new.abb.com/drives/software-tools/drivesize>.



—
ACS880 Multidrives provide flexibility to ensure that even the larger drive can be modified to meet space requirements/to fit to available space on installation site. The modular structure of ACS880 Multidrives enable that drive line-up can be built and installed into straight line, L- and U-shape and back-to-back layouts.

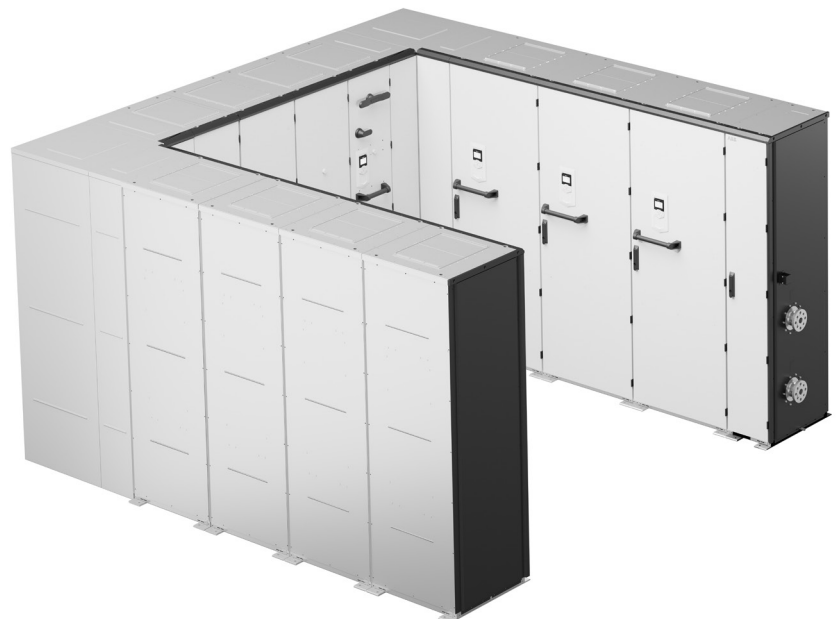

Fieldbus and Industrial Ethernet solutions

Easy, secure, and reliable integration with all automation ecosystems

Smooth data communication is central to running critical infrastructure, transportation, and industrial networks of all kinds. ABB is a technology leader in digital automation communication networks. We provide device integration, wireless and wired products, and systems that help you to make the Industrial Internet of Things a reality. ACS880 drives support all major fieldbus protocols, giving you the flexibility, compatibility, and security. As the standard, the drives come with Modbus RTU fieldbus interface module and drive-to-drive communication link.

The drives support advanced communication features:

- Accurate torque and speed control over the PROFINET or PROFIBUS
- Increased control system availability with the PROFINET S2 redundancy
- PROFIsafe over PROFINET
- CIP Safety
- Support for multiple protocols simultaneously
- Shared Ethernet connection for automation communication and Drive Composer pro PC tool – all communication via the same cable

To minimize connectivity-related risks, cybersecurity is a built-in, integral part of the ACS880.

To simplify ACS880's connectivity to automation systems, ABB offers support tools for seamless integration with PLCs from ABB and several other manufacturers.

Remote monitoring

With a built-in web server and standalone data logger, the NETA-21 remote monitoring tool enables secure worldwide access to your drives.

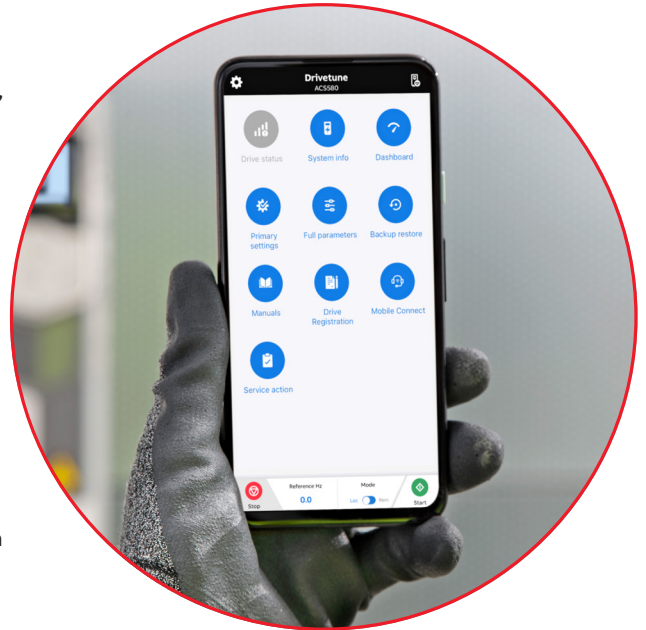

Better connectivity and user experience

Minimized downtime

Robust, long life time design

The ACS880 is designed to last for a long time, even in harsh conditions. The benefits include a nine-year maintenance interval and good tolerance for vibrations and contamination.

Several design features make the ACS880 a safe choice:

- Coated circuit boards
- Minimized air flow through the control board section
- Designed for ambient temperatures up to 50 °C
- Advanced protections – e.g. faster and more accurate IGBT protection using a thermal model

Each ACS880 drive unit is tested in the factory at full load to ensure maximum reliability. Continuous quality improvements are made based on the results of accelerated lifetime tests.



Removable memory unit

The memory unit stores the drive software and settings, including motor data. This unit can be switched from one drive to another, allowing simple and rapid drive replacement without any special equipment, software loading, parameter settings, or other adjustments in the drive or automation system. It also eliminates the risk of software incompatibility. The new drive is ready to run as soon as the memory unit is plugged in.

Nine-year maintenance interval

Advanced features for analyzing and resolving issues

The ACS880 has timers and counters that can be configured to remind you when the drive or process equipment needs maintenance.



Accurate and reliable diagnostic information is available for warning and fault messages. Help texts give detailed information about the warning or fault. Data loggers store critical values before and during an event, such as a fault. The real-time clock allows you to see the exact times of events.

For faster remote support, all relevant drive data and changed parameters can be saved in a single file package that you can easily create with the PC tool or by creating a QR code with the control panel.

Global support

For true global coverage, ABB offers worldwide support via its extensive pre- and after-sales network, structured to make sure that you have the experts you need close by, locally and globally. See pages 76-77.

Protect your people, machinery, and processes with integrated drive safety

Maximized safety and conformity

The Safe Torque Off (STO) safety function comes integrated into ACS880 drives. Optional safety functions modules provide an easy way to extend safety functions. These plug-in modules are installed and cabled inside the drive, enabling safety functions and diagnostics in one compact and reliable module. The safety functions are certified by TÜV Nord and comply with the highest performance requirements in machinery safety – SIL 3 / PL e*).

Increased productivity by doing things smarter

Safety functions help to minimize unnecessary downtime by keeping the application in control at all times. Safely-Limited Speed (SLS), for example, keeps the process running at a safe speed instead of stopping it.

Flexibility and ease of use

The safety functionality can be scaled to your needs. From STO wired to an emergency stop push button, to a complete safety system with PROFIsafe and a safety PLC, e.g. the AC500-S.

Configuring the safety functions module is easy thanks to the graphical user interface of the Drive Composer pro PC tool.

Available safety functionality

The following safety functions are supported:

- Safe Torque Off (STO)
- Safe Stop 1 (SS1-t and SS1-r)
- Safe Stop Emergency (SSE)
- Safe Brake Control (SBC)
- Safely-Limited Speed (SLS)
- Safe Maximum Speed (SMS)
- Prevention Of Unexpected Startup (POUS)
- Safe Direction (SDI)
- Safe Speed Monitor (SSM)
- Safe Motor Temperature (SMT)

Integrated safety simplifies configuration

Safety for explosive atmospheres

ACS880 and ABB Ex motors have been certified as a package providing a safe, proven solution for explosive atmospheres. ACS880 safety options for ATEX environments:

- ATEX-approved thermistor protection module
- ATEX-approved Safe Torque Off

TÜV-certified safety design tool

The FSDT-01 functional safety design tool can be used to design complete safety circuits. With this tool it is possible to define required safety integrity (SIL) / performance level (PL) for safety functions, verify achieved safety level and generate design reports.

*) SIL 2 / PL c for SMT (Safe Motor Temperature)



Global compatibility with various demands

Global product approvals and support

The ACS880 is a global product and has all the major global approvals, such as CE, UL, cUL, EAC, RCM and TÜV. Industry-specific approval, like different kinds of marine approval, ATEX and SEMI F47 are available either as standard or as an option.



Support for different motor types

The ACS880 provides reliable control for various motors, such as squirrel cage, high-torque or permanent magnet, Synchronous reluctance (SynRM), permanent magnet assisted SynRM (PMaSynRM) and high-speed motors and synchronous machines with external excitation. Practically any encoder type is supported.

Regardless of the motor type, drive commissioning is easy, with no need for laborious manual tuning.

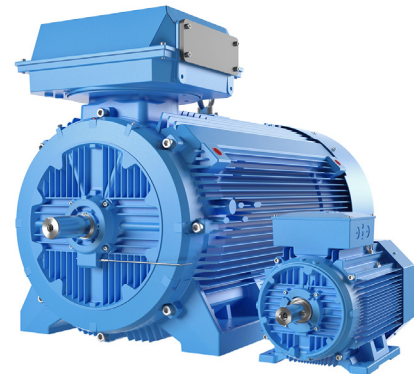

Low harmonic content

All ACS880 drives have a choke for harmonic reduction. If lower harmonic content is needed, an IGBT supply unit can be used. It produces exceptionally low harmonic content and meets the requirements of harmonics recommendations like IEEE519, IEC61000-3-12 and G5/4.

Regeneration of energy

The ACS880 offers a number of solutions for applications where electrical braking is needed. As standard, ACS880 drives have a flux braking feature that provides greater deceleration by increasing the motor flux. If this is not sufficient, optional brake unit can be used together with a brake resistor.

Multidrive's common DC bus configuration also allows the braking energy from one load to be utilized by other loads.

The most advanced solution is to use an IGBT supply unit for regeneration. It allows full, continuous braking, providing the possibility for remarkable energy savings.

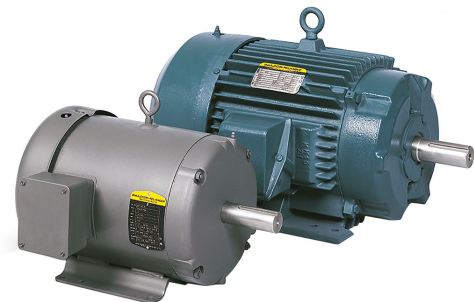

Premium control and programmability

Direct torque control (DTC)

ABB's state of the art motor control technology provides precise speed and torque control, with or without an encoder, even close to zero speed. DTC provides reliable starts and rapid reactions to load or network changes, and ensures smooth and continuous operation. DTC provides optimal control, even with sine filters.

The energy optimizer feature maximizes motor efficiency by ensuring maximum torque per ampere, reducing the power drawn from the supply.

Position control and synchronizing

Position control allows to meet motion systems demands without the need of an external position controller. The ready-made motion functions can be easily configured by parameters.

For optimized solution for your application, the functions can be modified and extended by IEC 61131 programming using PLCopen motion blocks.

Additional features, such as built-in synchronized drive to drive link and possibility for encoderless positioning, make ACS880 position control ideal for any axis.

Drive programming

To meet your specific application needs, you can customize your ACS880 with an extensive range of user-definable software settings (parameters) and adaptive programming. This makes fine-tuning the ready-made application control program functionalities easy. For further customization, drive application programming based on IEC 61131 standard is available for full PLC programmability. IEC programming uses the same programming environment as ABB PLCs. It is also easy to integrate the ACS880 with other components, such as PLCs and HMIs.

Adaptive programming

is an easy to use dynamic programming which allows flexible adjustments to the ACS880 software.

IEC programming

based on IEC 61131 standard for full scale PLC programmability is available as an option.

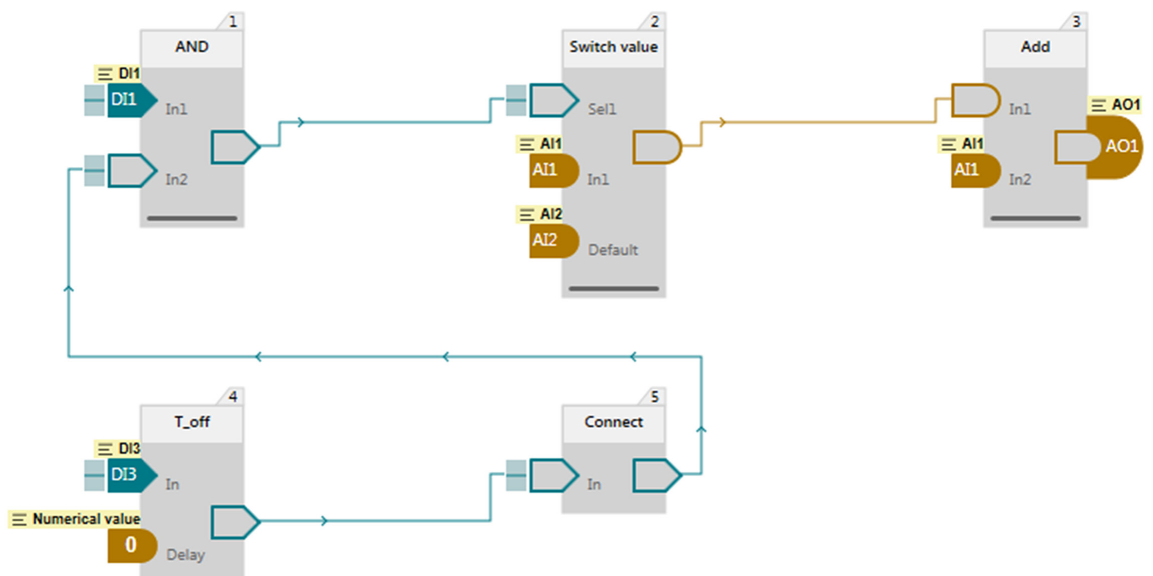



Application- and industry-specific solutions

Cranes (EOT cranes), +N5050

- Mechanical brake control
- Slow down and end limit logic
- Antisway
- Hoist speed optimization
- Shaft synchro

Winches, +N5100

- Mooring
- Anchor control
- Accurate open loop speed & torque control
- Winch interface for multiple control stands

Winders, +N5000

- Roll diameter calculation
- Tension control
- Dancer and load cell control
- Inertia and friction compensation

Artificial oil lifting, PCP +N5200

- Backspin control
- Automatic pump speed control
- Induction and PM motor control
- Protections for pump mechanics

Optimal grid control, +N8053

- Creation of an island AC grid
- Support the operation of a distributed power system



By working closely with customers over many years, ABB has developed application control programs and software features for specific applications and industries. This results in programs and features that include lessons learned from many customers, and that are designed to give you the flexibility to adapt the programs to your specific needs.

Advantages:

- Enhanced application usability
- Lower energy consumption
- Increased safety
- Reduced need for PLCs
- Protected machinery
- Optimized application productivity
- Optimized time usage and lower operational costs



LV synchronous machine, +N8052

- Machine model based flux and torque control
- Machine saturation model
- Excitation current reference calculation
- Autophasing function

Test bench, +N5300

- Fast communication
- High torque accuracy and linearity
- Acceleration damping
- Minimized motor noise

High speed test bench, +P967

- High-speed test benches up to 25 000 rpm
- For air-cooled inverter units -107 (INU) R8i frames

Chemical industry

- Direct torque control with sine filters
- Nine-year service interval
- Functionality that conforms with NAMUR requirements

Explosive atmospheres

- Type approval with ABB Ex motors
- ATEX-approved Safe Torque Off, STO (+Q971) and thermistor protection module (+L537)

Marine

- Type approval from various key classification bodies (+C132)
- Optimal grid control for shore-to-ship and hotel load applications
- Product certification process (+C20X)

Hydrogen production

- DC supply for electrolysis
- Optional DC/DC-converter for superior DC voltage

Technical data

Mains connection	
Voltage and power range	3-phase, U_{N3} 380 to 415 V, +10%/-10% 3-phase, U_{N5} 380 to 500 V, +10%/-10% 3-phase, U_{N7} 525 to 690 V, +10%/-10% Inverter unit (INU) 1.5 to 6000 kW Diode supply unit (DSU) 50 to 5500 kVA IGBT supply unit (ISU) 300 to 6944 kVA Regenerative rectifier unit (RRU) 400 to 6100 kVA
Frequency	50/60 Hz $\pm 5\%$
Power factor	IGBT supply unit (ISU): - $\cos\phi = 1$ (fundamental) - $\cos\phi = 0.99$ (total) Diode supply unit (DSU) and regenerative rectifier unit (RRU): - $\cos\phi = 0.98$ (fundamental) - $\cos\phi = 0.93$ to 0.95 (total)
Efficiency (at nominal power)	98% with DSU and RRU 97.5% with ISU
Motor connection	
Voltage	3-phase output voltage 0 to $U_{N3} / U_{N5} / U_{N7}$
Frequency	0 to ± 598 Hz ³⁾
Motor control	Direct torque control (DTC)
Torque control	Torque step rise time: Open loop - < 5 ms with nominal torque Closed loop - < 5 ms with nominal torque Non-linearity: Open loop - $\pm 4\%$ with nominal torque Closed loop - $\pm 3\%$ with nominal torque
Speed control	Static accuracy: Open loop - 10% of motor slip Closed loop - 0.01% of nominal speed Dynamic accuracy: Open loop - 0.3 to 0.4% seconds with 100% torque step Closed loop - 0.1 to 0.2% seconds with 100% torque step
Product compliance	
CE, UKCA Low Voltage Directive 2014/35/EU according to EN 61800-5-1:2007+A1:2017+A11:2021 SGS statement according to IEC 61800-5-1 Machinery Directive 2006/42/EC EMC Directive 2014/30/EU ATEX Directive 2014/34/EU, EN 50495 Quality assurance system ISO 9001 and Environmental system ISO 14001 RoHS 2011/65/EU and Delegated Directive (EU) 2015/836 cULus listed according to UL 508A and CSA C22.2 No. 14, CSA certified according to CSA C22.2 No. 14 ⁸⁾ RCM, EAC ²⁾ TÜV Nord certification for functional safety ⁵⁾ ATEX-certified safe disconnection function and thermistor & PT100 protection functions, Ex II (2) GD ⁶⁾ UKEX Type Examination certificates for safe disconnection function and thermistor and PT100 protection functions, Ex II (2) GD 6) Marine type approvals: ABS, BV, CCS, ClassNK, DNV GL, KR, LR, RINA For product specific availability, see https://new.abb.com/drives/segments/marine/marine-type-approvals	
EMC according to EN 61800-3: 2004 + A1: 2012. See page 61.	
1 st environment, restricted distribution category C2, as option 1000 A and up to 500 V 2 nd environment, unrestricted distribution category C3, as option	
Built-in functional safety. See pages 58 - 59.	
For Safe Torque Off (STO) and safety functions modules	EN/IEC 61800-5-2, IEC 61508: SIL 3, IEC 61511: SIL 3, EN/IEC 62061: SIL CL 3, EN ISO 13849-1: PL e – TÜV Nord certified ⁵⁾
Safety over fieldbus	PROFIsafe over PROFINET, certified.

Environmental limits	
Ambient temperature	
Transport	-40 to +70 °C
Storage	-40 to +70 °C
Operation area (air-cooled)	0 to +40 °C, no frost allowed +40 to 50 °C with derating of 1%/1 °C
(liquid-cooled)	0 to +45 °C, no frost allowed +45 to +55 °C with derating of 0.5%/1 °C
Cooling method	
Air-cooled	Dry clean air
Liquid-cooled	Direct liquid-cooling, coolant Antifrogen® L Incoming coolant temperature to module (-x07LC): - 0 to +40 °C as standard - +40 to +45 °C with derating of 2%/1 °C - +45 to +50 °C with derating of 2%/1 °C or 6%/1 °C ⁷⁾ Incoming coolant temperature to optional liquid-cooling unit (-1007LC) (fresh water or sea water): - 0 to +36 °C as standard - +36 to +46 °C with derating of 2%/1 °C
Altitude	
0 to 1,000 m	Without derating
1,000 to 4,000 m	With derating of 1% / 100 m ⁴⁾
Relative humidity	5 to 95%, no condensation allowed
Degree of protection	
Air-cooled	IP22 as standard (IP20 cabinet doors open) IP42 or IP54 as option
Liquid-cooled	IP42 as standard (IP20 cabinet doors open) IP54 as option
Paint color	RAL 9017, RAL 7035
Pollution degree	PD 2
Contamination levels	No conductive dust allowed
Storage	IEC 60721-3-1:1997, Class 1C2 (chemical gases), Class 1S2 (solid particles) ^{*)}
Operation	IEC 60721-3-3:2002, Class 3C2 (chemical gases), Class 3S2 (solid particles) ^{*)}
Transportation	IEC 60721-3-2:1997, Class 2C2 (chemical gases), Class 2S2 (solid particles) ^{*)}
Vibration	IEC 60068-2-6, 10 to 57 Hz 0.075 mm displacement amplitude 57 to 150 Hz 1 g Units with marine construction: - Max. 1 mm (peak value 2 to 13.2 Hz) - Max. 0.7 g (13.2 to 100 Hz) sinusoidal

^{*)} C = Chemically active substances

^{*)} S = Mechanically active substances

¹⁾ Operation above 120 Hz might require type specific derating, please contact your local ABB office

²⁾ EAC has replaced GOST R

³⁾ For higher operational output frequencies please contact your local ABB office

⁴⁾ Derating reduced by lower than 40 °C ambient temperature

⁵⁾ For available certificates, see <http://new.abb.com/drives/functional-safety>

⁶⁾ Thermistor protection function (+L537+Q971)
PTC/PT100 thermal motor protection (+L513/L514+Q971)

⁷⁾ See product specific hardware manual for detailed derating rules.

⁸⁾ UL/CSA panel shop standards that ACS880 multidrives complies with, only allow ambient temperature of 0...40C.

How to select a drive

The right drive is extremely easy to select. The following instructions show you how to order the right drive for your application.

Start by identifying your supply voltage and select the related rating table. Or use ABB's DriveSize dimensioning tool.

Select your inverter type from the rating table based on the load current, or, if it is unknown, select the drive based on your motor's power and current ratings.



Ratings, types and voltages
Inverter units, air-cooled, ACS880-107, 400 V

U_c = 400 V (range 230 to 415 V). The power ratings are valid at nominal voltage 400 V (0.9 to 0.989 kV) and U_c = 400 V (range 230 to 415 V). The power ratings are valid at nominal voltage 400 V (0.9 to 0.989 kV) and U_c = 400 V (range 230 to 415 V).

Inverter unit (DW)	Power class (kW)	400 V (range 230 to 415 V)			480 V (0.9 to 0.989 kV)			Notes	Mounting	IP
		I _n (A)	I _m (A)	I _r (A)	I _n (A)	I _m (A)	I _r (A)			
ACS880-107-0040A-3	B1	4.8	7.1	11.5	6.0	9.0	13.5	47	0.07	24
ACS880-107-0064A-3	B1	6	9.0	13.5	7.5	11.2	16.8	47	0.09	24
ACS880-107-0096A-3	B1	8	12.0	18.0	10.0	15.0	22.5	47	0.13	24
ACS880-107-0160A-3	B2	12	18.0	27.0	15.0	22.5	33.8	47	0.20	24
ACS880-107-0240A-3	B2	18	27.0	40.5	22.5	33.8	50.6	47	0.30	24
ACS880-107-0360A-3	B3	27	40.5	60.8	33.8	50.6	75.9	47	0.45	24
ACS880-107-0540A-3	B3	40.5	60.8	91.2	50.6	75.9	113.8	47	0.68	24
ACS880-107-0810A-3	B4	60.8	91.2	136.8	75.9	113.8	170.7	47	1.02	24
ACS880-107-1200A-3	B4	91.2	136.8	205.2	113.8	170.7	256.0	47	1.53	24
ACS880-107-1800A-3	B5	136.8	205.2	307.8	170.7	256.0	385.2	47	2.29	24
ACS880-107-2700A-3	B6	205.2	307.8	461.7	256.0	385.2	577.8	47	3.44	24
ACS880-107-4050A-3	B7	307.8	461.7	692.6	385.2	577.8	866.7	47	5.16	24
ACS880-107-6080A-3	B8	461.7	692.6	1038.9	577.8	866.7	1299.9	47	7.74	24
ACS880-107-9000A-3	B9	692.6	1038.9	1558.4	866.7	1299.9	1949.9	47	11.61	24

Ratings, types and voltages
Inverter units, air-cooled, ACS880-107, 400 V

U_c = 400 V (range 230 to 415 V). The power ratings are valid at nominal voltage 400 V (0.9 to 0.989 kV) and U_c = 400 V (range 230 to 415 V). The power ratings are valid at nominal voltage 400 V (0.9 to 0.989 kV) and U_c = 400 V (range 230 to 415 V).

Inverter unit (DW)	Power class (kW)	400 V (range 230 to 415 V)			480 V (0.9 to 0.989 kV)			Notes	Mounting	IP
		I _n (A)	I _m (A)	I _r (A)	I _n (A)	I _m (A)	I _r (A)			
ACS880-107-0040A-3	B1	4.8	7.1	11.5	6.0	9.0	13.5	47	0.07	24
ACS880-107-0064A-3	B1	6	9.0	13.5	7.5	11.2	16.8	47	0.09	24
ACS880-107-0096A-3	B1	8	12.0	18.0	10.0	15.0	22.5	47	0.13	24
ACS880-107-0160A-3	B2	12	18.0	27.0	15.0	22.5	33.8	47	0.20	24
ACS880-107-0240A-3	B2	18	27.0	40.5	22.5	33.8	50.6	47	0.30	24
ACS880-107-0360A-3	B3	27	40.5	60.8	33.8	50.6	75.9	47	0.45	24
ACS880-107-0540A-3	B3	40.5	60.8	91.2	50.6	75.9	113.8	47	0.68	24
ACS880-107-0810A-3	B4	60.8	91.2	136.8	75.9	113.8	170.7	47	1.02	24
ACS880-107-1200A-3	B4	91.2	136.8	205.2	113.8	170.7	256.0	47	1.53	24
ACS880-107-1800A-3	B5	136.8	205.2	307.8	170.7	256.0	385.2	47	2.29	24
ACS880-107-2700A-3	B6	205.2	307.8	461.7	256.0	385.2	577.8	47	3.44	24
ACS880-107-4050A-3	B7	307.8	461.7	692.6	385.2	577.8	866.7	47	5.16	24
ACS880-107-6080A-3	B8	461.7	692.6	1038.9	577.8	866.7	1299.9	47	7.74	24
ACS880-107-9000A-3	B9	692.6	1038.9	1558.4	866.7	1299.9	1949.9	47	11.61	24

Drive Assistant Control panels

Standard Bluetooth assistant control panel, ACS-AP-W and industrial assistant control panel, ACS-AP-I
Assistant control panel with clear multilingual graphical display can be used for parameter setting and back-up, drive monitoring and operation, fault tracing and a USB for PC tool. There are two different assistant control panels – with ACS-AP-W or without ACS-AP-W. The panels can be incorporated either on the drive or on the door of the enclosure and they are compatible with any ABB air-cooled drive.

Control panel mounting platform, DMPH-02
Is for flush mounting and has IP65 / UL Type 12 protection class (IP20, when control panel is not mounted). Supports direct chattering of the control panel link.

Control panel mounting platform, DMPH-04
Is for flush mounting and has IP65 / UL Type 12 protection class (IP20, when control panel is not mounted).

Control panel mounting platform, DMPH-04
Is for flush mounting and has IP65 / UL Type 12 protection class (IP20, when control panel is not mounted). Supports direct chattering of the control panel link.

Control panel mounting platform, DMPH-04
Is for flush mounting and has IP65 / UL Type 12 protection class (IP20, when control panel is not mounted).

Control panel mounting platform, DMPH-04
Is for flush mounting and has IP65 / UL Type 12 protection class (IP20, when control panel is not mounted).

Drive Connectivity Panel
Control panel variant with built-in Bluetooth and mobile radio. It offers easy remote condition monitoring, plug, and play installation with secure and reliable wireless connection to the ABB Ability™ Digital PowerView, the cloud-based condition monitoring portal for ABB Drives. Possible to connect with the DriveView mobile app and Drive Computer Entry PC tool as well. Available with a removable subscription to the ABB Ability™ Digital PowerView™.

Control panel options
The control panel options are available on all ACS-AP-W and ACS-AP-I panels. The options are included as standard in the delivery. ACS-AP-W DMPH02 can be replaced by 0 option below.

Code	Description	Description	Type
0	No control panel		None
01	Standard Bluetooth assistant control panel ACS-AP-W	Bluetooth Assistant control panel, included as standard.	ACS-AP-W
02	Industrial assistant control panel ACS-AP-I	Industrial assistant control panel, included as standard.	ACS-AP-I
03	Control panel mounting platform, flush mounting, IP65 / UL Type 12 (does not include control panel)	DMPH-02	DMPH-02
04	Control panel mounting platform, flush mounting, IP65 / UL Type 12 (does not include control panel)	DMPH-04	DMPH-04
05	Control panel mounting platform, flush mounting, IP65 / UL Type 12 (does not include control panel)	DMPH-04	DMPH-04

Choose your options and add the option codes to the drive's order code. Remember to use a "+" mark before each option code.

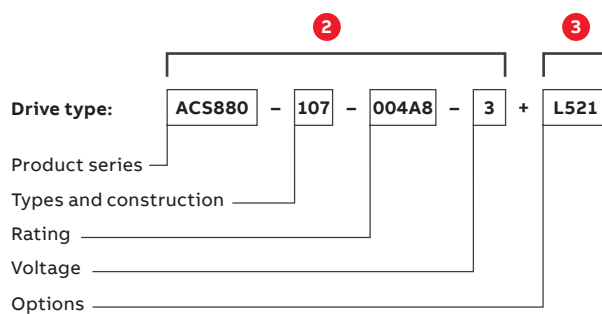

ACS880 multidrives

— 01
 Multidrive configuration with supply unit, DC bus and multiple inverters

— 02
 Multidrives are constructed for controlling multiple motors. The most important units are: drive units (known as inverter units (INU)) and supply units (DSU/RRU/ISU).

The multidrives principle is based on a common DC bus arrangement, enabling single power entry and common braking resources for several drives. There are several possibilities on the supply side starting from a simple diode supply unit up to highly sophisticated active IGBT supply units.

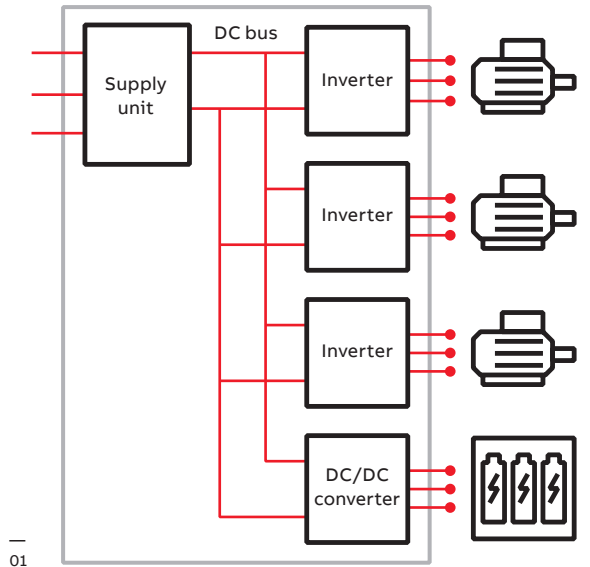

— 02

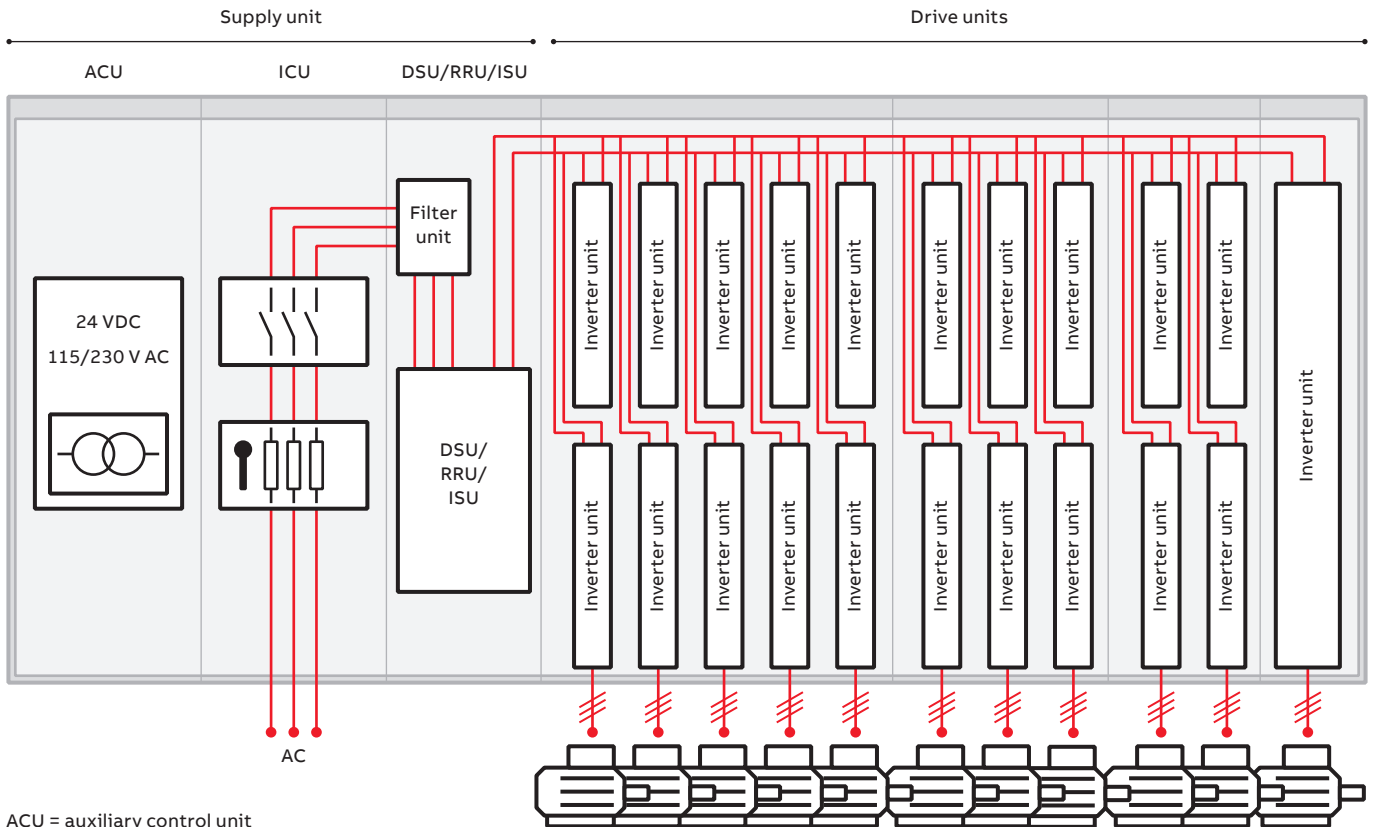

ACU = auxiliary control unit
 ICU = incoming unit
 DSU = diode supply unit
 RRU = regenerative rectifier unit
 ISU = IGBT supply unit

—
03
ACS880-104 inverters
modules, frame
sizes R1i to R8i



—
03

Multidrives can be used wherever several motors form part of a single process. With a compact module design and high power density, the single supply and DC bus arrangement with multiple inverters provides many advantages:

- Savings in cabling, installation and maintenance costs
- Reduced component count and footprint, as well as increased reliability
- Energy and cost savings. As the energy circulates over the common DC bus, all energy is not taken from the supply network. Energy circulation can also be used for motor-to-motor braking without the need for a braking chopper or regenerative supply unit.
- Reduced line power and currents allowing the supply unit to have smaller dimensions.
- The common supply of the multidrives enables the implementation of overall safety and control functions.

In multimotor applications, for example in a paper machine, the individual inverter modules provide fast communication of torque and speed signals between the inverters for controlling the tension in the paper web. Also in cases where the shafts of the individual motors are not tightly coupled, for example in sugar centrifuges, each inverter module can be programmed with a speed profile in order to minimize overall energy consumption. These two examples merely demonstrate the range of applications where multidrives offer substantial benefits over other types of drive constructions. High power units D7T, D8T, R6i, R7i and nxR8i have speed controlled cooling fans as a standard.

ACS880 multidrives

Inverter units (INU)

Inverter units are DC supplied and have built-in capacitors for smoothing the DC voltage. The electrical connection to the common DC bus is fuse protected. An individual inverter unit can be disconnected from the DC bus, either by a fuse disconnecter or by a DC switch.

Diode supply unit (DSU)

A diode supply unit is used in non-regenerative drive systems to convert three-phase AC voltage to DC voltage. Two types of diode supply units are available: an uncontrolled 6-pulse diode supply unit (D6D to D8D) and a half-controlled 6/12-pulse diode supply unit with thyristor charging (D7T and D8T). The DXT modules can be connected parallel and are able to charge the inverters without external components.

IGBT supply unit (ISU)

IGBT supply units are used in regenerative drives to convert three-phase AC voltage to DC voltage. The ISU consists of R8i and LCL filter modules. It can operate in both motoring and generating modes. The DC voltage is constant and the line current is sinusoidal. The control also provides a near unity power factor. The supply unit can also boost DC voltages e.g. when line voltage is low. Harmonic content remains extremely low due to DTC control and LCL line filtering. ISU is very tolerable to network voltage variations.

Regenerative rectifier unit (RRU)

This supply unit is used in regenerative drive systems to convert three-phase AC voltage to DC voltage. The RRU is made of $n \times R8i$ and L filter modules. During motoring the input current flows through the diodes to the DC bus and the supply unit works as a diode bridge. In regeneration the current flows from the DC bus through the IGBTs to the supply network. The IGBTs' are switched to conduct only once during each network voltage cycle. This reduces switching losses and enables high input and output powers of the R8i module. Unlike with a thyristor bridge, the IGBTs can be switched off at any time which improves reliability. Operation of RRU is also reliable during supply network voltage variations.

Brake unit

Brake unit is used for resistor braking. It handles the energy generated by decelerating motors for example in emergency stopping. Whenever the voltage in the common DC bus exceeds a certain limit, a braking chopper connects the bus to a braking resistor. Offering includes 1-phase brake unit and 3-phase dynamic brake unit (DBU) which utilizes R8i modules.

DC/DC converter (DDC)

DC/DC converter transfers energy from a common DC bus of a multidrive into an external energy storage. From there it can transfer the energy back to the DC bus when needed. Energy storages can be batteries or super capacitors. Applications for energy storage and reuse are found in a range of industries, such as marine (heave and peak load compensation), process industry (electrical braking or DC bus voltage stabilization) and automotive (charging systems). Customer benefits include reduced costs (less fuel consumption, less or smaller generators in ships), improved ship performance and safety in critical situations. The converter unit consists of R8i and DCL filter modules.

AC 800M control unit (optional)

The multidrive concept also includes the control unit for the AC 800M process controller and S800 I/O system. The control unit is equipped with communication interfaces, power supplies and the front devices necessary for the automation equipment.

Unit	Unit type	Type code	
		Air-cooled	Liquid-cooled
INU	Inverter unit	ACS880-107	ACS880-107LC
DSU	Diode supply unit	ACS880-307	ACS880-307LC
ISU	IGBT supply unit	ACS880-207	ACS880-207LC
RRU	Regenerative rectifier unit	ACS880-907	–
DBU	Brake unit	ACS880-607	ACS880-607LC
DDC	DC/DC converter	ACS880-1607	ACS880-1607LC

—
01
Multidrive configuration
with supply unit, DC bus
and multiple inverters



—
01

ACS880 air-cooled multidrives

- Power ratings:
 - Inverter units (INU): 1.5 to 5600 kW
 - Diode supply units (DSU): 50 to 5500 kVA
 - IGBT supply units (ISU): 300 to 6100 kVA
- Regenerative rectifier units (RRU):
 - 416 to 6100 kVA
- Brake units:
 - 1-phase P_{cont} 54 to 714 kW
 - 3-phase $P_{cont,max}$ 500 to 6500 kW
- DC/DC converters (DDC):
 - 305 to 1146 kW
- Voltage range:
 - 380 to 690 V
- Enclosure classes:
 - IP22 (as standard), IP42 and IP54

Multidrives have an extensive selection of built-in features and options. See page 79.

Highlights

- Compact design for easy cabinet assembly and maintenance
- High packing density, for example 16 units of frame size R2i inverters can be installed into a one meter wide cabinet
- Diode bridge that is highly reliable with high power density
- Fast connectors for motor cables in the bottom part of the cabinet making installation easy
- Degree of protection IP22, IP42 and IP54 for different environments
- Device panel for optional switches and pilot light
- Cabinet light and heater option
- Highly efficient thermal handling as heat loss of each inverter unit is guided to the back of the cabinet. All cabinets are their own compartments.
- Long lifetime capacitors and high efficiency cooling fan with speed or on-off control

ACS880 liquid-cooled multidrives

The compact and robust ACS880 liquid-cooled drives with direct liquid cooling are an ultimate solution for various applications where space savings, silent operation or durability in harsh environments is a must.

Advanced liquid-cooling and compact design

Liquid-cooling offers easy heat transfer without air filtering problems. Since the coolant takes care of 98% of the heat losses, no additional filtered air-cooling is needed. This increases the total efficiency of the drive installation.

The liquid-cooled drives have high power density making their design extremely compact. The small footprint enables significant space and weight reduction.

Optimal solution for different environments

The possibility to have totally enclosed cabinet structure makes the ACS880 liquid-cooled drive perfect for harsh environmental conditions.

The offering fulfills marine and offshore requirements. The drive has marine type approvals from various key classification bodies.

As the direct liquid cooling enables silent operation, liquid-cooled drives are suitable for applications where noise levels are an important environmental factor.

Simple and cost-efficient installation

The high-efficient liquid cooling removes the need for air-conditioning in the installation rooms, bringing the installation and operation costs down. As there is no need for additional air conditioning devices or air ducts, the installation is significantly simplified. Liquid cooling also enables heat recovery when process heat is needed, which can help to reduce CO₂ footprint.

The used coolant type is Antifrogen® L, by Clariant International Ltd, cooling liquid with glycol and inhibitor. It is a ready-made, commercially available mix, which enables easy commissioning and prevents the risk of errors in coolant selection.

Optimal for harsh environmental conditions

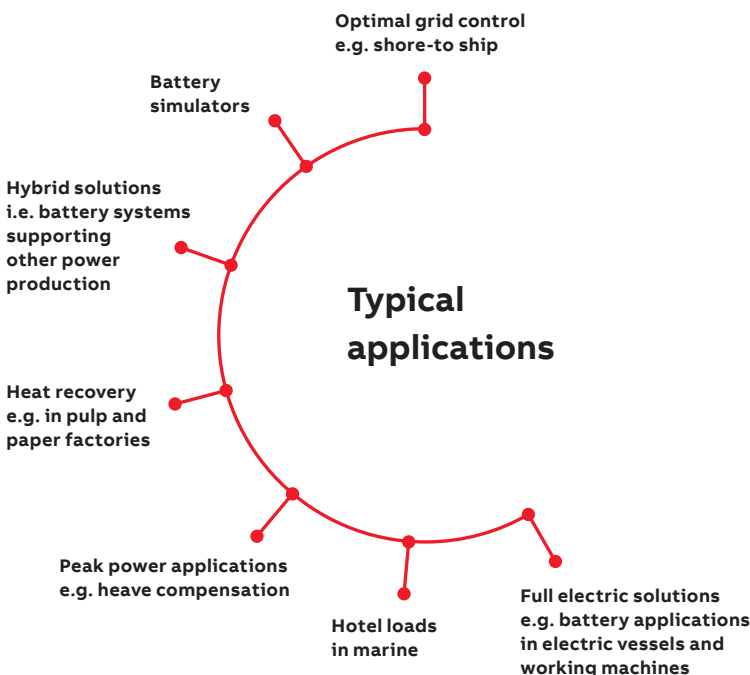

Robust, reliable and compact

—
01
Liquid-cooled multidrive
configuration



—
01

ACS880 liquid-cooled multidrives

- Power ratings:
 - Inverter units (INU): 55 to 6000 kW
 - IGBT supply units (ISU): 430 to 6944 kVA
- Brake units:
 - P_{cont} 54 to 714 kW
- DC/DC converters (DDC):
 - 351 to 1581 kW
- Voltage range:
 - 690 V
- Enclosure classes:
 - IP42 (as standard) and IP54
- Liquid-cooling unit:
 - 70 to 195 kW cooling power with single and redundant pump versions
 - Built-in cabinet heater
 - Heat exchanger for industrial cooling water
 - Various external pipe connection solutions and sea water heat exchanger available as engineered variants

Multidrives have an extensive selection of built-in features and options. See page 79.

Highlights

- Advanced liquid-cooling which reduces the need for air-cooling in installation rooms
- High power density with compact design
- Optimized design for cabinet assembly
- Silent operation
- Suitable for harsh environments
- Marine approvals from various key classification bodies

Ratings, types and voltages

Inverter units, air-cooled, ACS880-107, 400 V

$U_N = 400$ V (range 380 to 415 V). The power ratings are valid at nominal voltage 400 V (1.5 to 2800 kW).

Drive type	Frame size	Nominal ratings			Light overload use		Heavy-duty use		Noise level (dB(A))	Heat dissipation (kW)	Air flow (m ³ /h)
		I_N AC (A)	I_{MAX} AC (A)	P_N (kW)	I_{Ld} (A)	P_{Ld} (kW)	I_{Hd} (A)	P_{Hd} (kW)			
Inverter units (INU), ACS880-107											
ACS880-107-004A8-3	R1i	4.8	7	1.5	4.5	1.5	4	1.5	47	0.07	24
ACS880-107-006A0-3	R1i	6	8.8	2.2	5.5	2.2	5	1.5	47	0.08	24
ACS880-107-008A0-3	R1i	8	10.5	3	7.6	3	6	2.2	47	0.09	24
ACS880-107-0011A-3	R2i	10.5	13.5	4	9.7	4	9	3	39	0.11	48
ACS880-107-0014A-3	R2i	14	16.5	5.5	13	5.5	11	4	39	0.14	48
ACS880-107-0018A-3	R2i	18	21	7.5	16.8	7.5	14	5.5	39	0.17	48
ACS880-107-0025A-3	R3i	25	33	11	23	11	19	7.5	63	0.2	142
ACS880-107-0035A-3	R3i	35	44	15	32	15	29	11	63	0.3	142
ACS880-107-0044A-3	R3i	44	53	18.5	41	18.5	35	15	71	0.35	200
ACS880-107-0050A-3	R3i	50	66	22	46	22	44	22	71	0.41	200
ACS880-107-0061A-3	R4i	61	78	30	57	30	52	22	70	0.5	290
ACS880-107-0078A-3	R4i	78	100	37	74	37	69	30	70	0.6	290
ACS880-107-0094A-3	R4i	94	124	45	90	45	75	37	70	0.74	290
ACS880-107-0100A-3	R4i	104	125	55	100	55	78	37	70	0.75	290
ACS880-107-0140A-3	R6i	141	183	75	135	75	105	55	71	1.1	650
ACS880-107-0170A-3	R6i	169	220	90	162	90	126	55	71	1.4	650
ACS880-107-0210A-3	R6i	206	268	110	198	110	154	75	71	1.8	650
ACS880-107-0250A-3	R6i	246	320	132	236	132	184	90	71	2	650
ACS880-107-0300A-3	R7i	300	390	160	288	160	224	110	72	2.5	940
ACS880-107-0350A-3	R7i	350	455	200	336	160	262	132	72	3.1	940
ACS880-107-0470A-3	R8i	470	620	250	451	250	352	160	72	4.8	1300
ACS880-107-0640A-3	R8i	640	840	355	614	315	479	250	72	6.7	1300
ACS880-107-0760A-3	R8i	760	990	400	730	400	568	315	72	8	1300
ACS880-107-0900A-3	R8i	900	1080	500	864	450	673	355	72	10	1300
ACS880-107-1250A-3	2×R8i	1250	1630	710	1200	630	935	500	74	13	2600
ACS880-107-1480A-3	2×R8i	1480	1930	800	1421	800	1107	630	74	16	2600
ACS880-107-1760A-3	2×R8i	1760	2120	1000	1690	900	1316	710	74	20	2600
ACS880-107-2210A-3	3×R8i	2210	2880	1200	2122	1200	1653	900	76	23	3900
ACS880-107-2610A-3	3×R8i	2610	3140	1400	2506	1400	1952	1000	76	30	3900
ACS880-107-3450A-3	4×R8i	3450	4140	1800	3312	1800	2581	1400	76	40	5200
ACS880-107-4290A-3	5×R8i	4290	5150	2400	4118	2000	3209	1800	77	50	6500
ACS880-107-5130A-3	6×R8i	5130	6160	2800	4925	2400	3837	2000	78	60	7800

Nominal ratings

I_N	Rated current available continuously without overloadability at 40 °C.
S_N	Nominal apparent power.
P_N	Typical motor power in no-overload use.

Maximum output current

I_{max}	Maximum output current. Available for 10 seconds at start, then as long as allowed by drive temperature.
-----------	--

Light-overload use

I_{Ld}	Continuous current allowing 110% I_{Ld} for 1 minute every 5 minutes at 40 °C.
P_{Ld}	Typical motor power in light-overload use.

Heavy-duty use

I_{Hd}	Continuous current allowing 150% I_{Hd} for 1 minute every 5 minutes at 40 °C.
P_{Hd}	Typical motor power in heavy-duty use.

The ratings apply at 40 °C ambient temperature. At higher temperatures (up to 50 °C) the derating is 1%/1 °C.

The current ratings are the same regardless of the supply voltage within one voltage range. Dimensioning has to be checked by DriveSize.

Ratings, types and voltages

Supply units, air-cooled, ACS880-x07, 400 V

$U_N = 400$ V (range 380 to 415 V)

Drive type	Frame size	Nominal ratings				No overload use	Light overload use		Heavy-duty use		Noise level (dB(A))	Heat dissipation (kW)	Air flow (m ³ /h)
		I_N AC (A)	I_N DC (A)	I_{Max} DC (A)	S_N (kVA)	P_N DC (kW)	I_{Ld} DC (A)	P_{Ld} DC (kW)	I_{Hd} DC (A)	P_{Hd} DC (kW)			
IGBT supply units (ISU), ACS880-207													
ACS880-207-0420A-3	R8i + BLCL-13-5	423	513	667	293	290	492	279	384	217	72	6.6	2200
ACS880-207-0580A-3	R8i + BLCL-13-5	576	698	908	399	395	670	379	522	296	72	9.3	2200
ACS880-207-0810A-3	R8i + BLCL-15-5	810	982	1277	561	556	943	553	735	416	72	13.3	2200
ACS880-207-1130A-3	2×R8i + BLCL-24-5	1125	1364	1773	779	772	1309	741	1020	577	74	17.2	4100
ACS880-207-1330A-3	2×R8i + BLCL-24-5	1332	1615	2100	923	914	1550	877	1208	683	74	19.5	4100
ACS880-207-1580A-3	2×R8i + BLCL-25-5	1584	1921	2497	1097	1086	1844	1043	1437	813	74	26	4100
ACS880-207-2350A-3	3×R8i + 2×BLCL-24-5	2349	2848	3703	1627	1611	2734	1547	2130	1205	76	40	6900
ACS880-207-3110A-3	4×R8i + 2×BLCL-25-5	3105	3765	4894	2151	2130	3614	2045	2816	1593	76	52.1	8200
ACS880-207-4620A-3	6×R8i + 3×BLCL-25-5	4617	5598	7278	3199	3167	5374	3040	4187	2369	78	78.1	12300
Regenerative rectifier units (RRU), ACS880-907													
ACS880-907-0600A-3	R8i + BL-15-5	600	727	955	416	393	698	377	544	294	72	8.4	2200
ACS880-907-0900A-3	R8i + BL-15-5	900	1091	1433	624	589	1048	566	816	441	72	12.9	2200
ACS880-907-1180A-3	2×R8i + BL-25-5	1180	1431	1879	818	773	1374	742	1070	578	74	15.7	4100
ACS880-907-1770A-3	2×R8i + BL-25-5	1770	2146	2818	1226	1159	2060	1113	1605	867	74	25.2	4100
ACS880-907-2310A-3	4×R8i + 2×BL-25-5	2310	2801	3678	1600	1512	2689	1452	2095	1131	76	31.5	8200
ACS880-907-3460A-3	4×R8i + 2×BL-25-5	3460	4195	5509	2397	2265	4027	2175	3138	1695	76	50.4	8200
ACS880-907-5130A-3	6×R8i + 3×BL-25-5	5130	6220	8168	3554	3359	5971	3225	4653	2512	78	75.6	12300
Diode supply units (DSU), ACS880-307													
6-pulse diode													
ACS880-307-0080A-3+A003	D6D ¹⁾	80	98	137	55	53	94	51	78	42	62	1.4	720
ACS880-307-0170A-3+A003	D6D ¹⁾	173	212	297	120	114	203	110	170	92	62	2	720
ACS880-307-0330A-3+A003	D7D ¹⁾	327	400	561	227	216	384	208	320	173	62	3	1070
ACS880-307-0490A-3+A003	D7D ¹⁾	490	600	840	339	324	576	311	480	259	62	4.1	1070
ACS880-307-0650A-3+A003	D8D ¹⁾	653	800	1120	452	432	768	415	640	345	65	5.8	1430
ACS880-307-0980A-3+A003	D8D ¹⁾	980	1200	1680	679	648	1152	622	960	519	65	7.6	1430
ACS880-307-0650A-3+A018	D8T ²⁾	653	800	1120	452	432	768	415	598	323	72	4.6	1300
ACS880-307-0980A-3+A018	D8T ²⁾	980	1200	1680	679	648	1152	622	898	485	72	6.6	1300
ACS880-307-1210A-3+A018	2×D8T ²⁾	1215	1488	2083	842	804	1428	771	1113	601	74	9.2	2600
ACS880-307-1820A-3+A018	2×D8T ²⁾	1823	2232	3125	1263	1205	2143	1157	1670	902	74	13.3	2600
ACS880-307-2730A-3+A018	3×D8T ²⁾	2734	3348	4687	1894	1808	3214	1736	2504	1352	76	19.9	3900
ACS880-307-3640A-3+A018	4×D8T ²⁾	3645	4464	6250	2525	2411	4285	2314	3339	1803	76	26.6	5200
ACS880-307-4560A-3+A018	5×D8T ²⁾	4557	5580	7812	3157	3013	5357	2893	4174	2254	77	33.3	6500
ACS880-307-5470A-3+A018	6×D8T ²⁾	5468	6696	9374	3788	3616	6428	3471	5009	2705	78	40	7800
12-pulse diode													
ACS880-307-0910A-3+A004+A018	2×D7T ³⁾	912	1116	1562	632	625	1071	600	835	467	74	8.4	1800
ACS880-307-1210A-3+A004+A018	2×D8T ³⁾	1215	1488	2083	842	833	1428	800	1113	623	74	9.2	2600
ACS880-307-1820A-3+A004+A018	2×D8T ³⁾	1823	2232	3125	1263	1250	2143	1200	1670	935	74	13.3	2600
ACS880-307-2430A-3+A004+A018	4×D8T ³⁾	2430	2976	4166	1684	1667	2857	1600	2226	1247	76	18.4	5200
ACS880-307-3640A-3+A004+A018	4×D8T ³⁾	3645	4464	6250	2525	2500	4285	2400	3339	1870	76	26.6	5200
ACS880-307-5470A-3+A004+A018	6×D8T ³⁾	5468	6696	9374	3788	3750	6428	3600	5009	2805	78	40	7800

¹⁾ +A003 6-pulse, uncontrolled diode bridge

²⁾ +A018 6-pulse, half controlled diode bridge

³⁾ +A004 12-pulse, DSU

Ratings, types and voltages

Inverter units, air-cooled, ACS880-107, 500 V

Inverter unit (INU), ACS880-107

$U_N = 500$ V (range 380 to 500 V). The power ratings are valid at nominal voltage 500 V (1.5 to 3200 kW).

Drive type	Frame size	Nominal ratings			Light overload use		Heavy-duty use		Noise level (dB(A))	Heat dissipation (kW)	Air flow (m ³ /h)
		I_N AC (A)	I_{MAX} AC (A)	P_N (kW)	I_{Ld} (A)	P_{Ld} (kW)	I_{Hd} (A)	P_{Hd} (kW)			
ACS880-107-003A6-5	R1i	3.6	5.3	1.5	3.4	1.5	3	1.5	47	0.06	24
ACS880-107-004A8-5	R1i	4.8	7	2.2	4.5	2.2	4	1.5	47	0.07	24
ACS880-107-006A0-5	R1i	6	8.8	3	5.5	3	5	2.2	47	0.08	24
ACS880-107-008A0-5	R1i	8	10.5	4	7.6	4	6	3	47	0.09	24
ACS880-107-0011A-5	R2i	10.5	13.5	5.5	9.7	5.5	9	4	39	0.13	48
ACS880-107-0014A-5	R2i	14	16.5	7.5	13	7.5	11	5.5	39	0.15	48
ACS880-107-0018A-5	R2i	18	21	11	16.8	11	14	7.5	39	0.18	48
ACS880-107-0025A-5	R3i	25	33	15	23	15	19	11	63	0.23	142
ACS880-107-0030A-5	R3i	30	36	18.5	28	18.5	24	15	63	0.28	142
ACS880-107-0035A-5	R3i	35	44	22	32	22	29	18.5	63	0.32	142
ACS880-107-0050A-5	R3i	50	66	30	46	30	44	22	71	0.48	200
ACS880-107-0061A-5	R4i	61	78	37	57	37	52	30	70	0.55	290
ACS880-107-0078A-5	R4i	78	100	45	74	45	69	45	70	0.65	290
ACS880-107-0094A-5	R4i	94	124	55	90	55	75	45	70	0.8	290
ACS880-107-0110A-5	R6i	113	147	75	108	75	85	55	71	1	650
ACS880-107-0140A-5	R6i	136	177	90	131	90	102	55	71	1.2	650
ACS880-107-0170A-5	R6i	165	215	110	158	110	123	75	71	1.5	650
ACS880-107-0200A-5	R6i	197	256	132	189	132	147	90	71	1.8	650
ACS880-107-0240A-5	R6i	240	312	160	230	160	180	110	71	2	650
ACS880-107-0300A-5	R7i	302	393	200	290	200	226	132	72	2.7	940
ACS880-107-0340A-5	R7i	340	442	250	326	200	254	160	72	3.2	940
ACS880-107-0440A-5	R8i	440	580	250	422	250	329	200	72	4.7	1300
ACS880-107-0590A-5	R8i	590	770	400	566	355	441	250	72	6.3	1300
ACS880-107-0740A-5	R8i	740	970	500	710	450	554	355	72	8.1	1300
ACS880-107-0810A-5	R8i	810	1060	560	778	500	606	400	72	9.3	1300
ACS880-107-1150A-5	2×R8i	1150	1500	800	1104	710	860	560	74	12	2600
ACS880-107-1450A-5	2×R8i	1450	1890	1000	1392	900	1085	710	74	16	2600
ACS880-107-1580A-5	2×R8i	1580	2060	1100	1517	1000	1182	800	74	18	2600
ACS880-107-2150A-5	3×R8i	2150	2800	1500	2064	1400	1608	1100	76	24	3900
ACS880-107-2350A-5	3×R8i	2350	3060	1600	2256	1500	1758	1200	76	27	3900
ACS880-107-3110A-5	4×R8i	3110	4050	2000	2986	2000	2326	1600	76	36	5200
ACS880-107-3860A-5	5×R8i	3860	5020	2400	3706	2400	2887	2000	77	44	6500
ACS880-107-4610A-5	6×R8i	4610	6000	3200	4426	2800	3448	2400	78	53	7800

Nominal ratings

I_N	Rated current available continuously without overloadability at 40 °C.
S_N	Nominal apparent power.
P_N	Typical motor power in no-overload use.

Maximum output current

I_{max}	Maximum output current. Available for 10 seconds at start, then as long as allowed by drive temperature.
-----------	--

Light-overload use

I_{Ld}	Continuous current allowing 110% I_{Ld} for 1 minute every 5 minutes at 40 °C.
P_{Ld}	Typical motor power in light-overload use.

Heavy-duty use

I_{Hd}	Continuous current allowing 150% I_{Hd} for 1 minute every 5 minutes at 40 °C.
P_{Hd}	Typical motor power in heavy-duty use.

The ratings apply at 40 °C ambient temperature. At higher temperatures (up to 50 °C) the derating is 1%/1 °C.

The current ratings are the same regardless of the supply voltage within one voltage range. Dimensioning has to be checked by DriveSize.

Ratings, types and voltages

Supply units, air-cooled, ACS880-x07, 500 V

Supply unit													
$U_N = 500 \text{ V}$ (range 380 to 500 V)													
Drive type	Frame size	Nominal ratings				No overload use	Light overload use		Heavy-duty use		Noise level	Heat dissipation	Air flow
		I_N AC (A)	I_N DC (A)	I_{MAX} DC (A)	S_N (kVA)		P_N DC (kW)	I_{Ld} DC (A)	P_{Ld} DC (kW)	I_{Hd} DC (A)			
IGBT supply units (ISU), ACS880-207													
ACS880-207-0400A-5	R8i + BLCL-13-5	396	480	624	343	340	461	326	359	254	72	6.7	2200
ACS880-207-0530A-5	R8i + BLCL-13-5	531	644	837	460	455	618	437	482	341	72	8.9	2200
ACS880-207-0730A-5	R8i + BLCL-15-5	729	884	1149	631	625	849	600	661	468	72	12.1	2200
ACS880-207-1040A-5	2×R8i + BLCL-24-5	1035	1255	1631	896	887	1205	852	939	664	74	16.5	4100
ACS880-207-1420A-5	2×R8i + BLCL-25-5	1422	1724	2241	1231	1219	1655	1170	1290	912	74	23.8	4100
ACS880-207-2120A-5	3×R8i + 2×BLCL-24-5	2115	2564	3334	1832	1813	2462	1741	1918	1356	76	35	6900
ACS880-207-2800A-5	4×R8i + 2×BLCL-25-5	2799	3394	4412	2424	2400	3258	2304	2539	1795	76	47.7	8200
ACS880-207-4150A-5	6×R8i + 3×BLCL-25-5	4149	5031	6540	3593	3557	4829	3415	3763	2661	78	71.5	12300
$U_N = 500 \text{ V}$ (range 230 to 525 V)													
Regenerative rectifier units (RRU), ACS880-907													
ACS880-907-0600A-5	R8i + BL-15-5	600	727	955	520	491	698	471	544	367	72	8.5	2200
ACS880-907-0900A-5	R8i + BL-15-5	900	1091	1433	779	737	1047	707	816	551	72	13	2200
ACS880-907-1180A-5	2×R8i + BL-25-5	1180	1431	1879	1022	966	1374	927	1070	722	74	16.1	4100
ACS880-907-1770A-5	2×R8i + BL-25-5	1770	2146	2818	1533	1449	2060	1391	1605	1084	74	25.6	4100
ACS880-907-2310A-5	4×R8i + 2×BL-25-5	2310	2801	3678	2001	1891	2689	1815	2095	1414	76	32.2	8200
ACS880-907-3460A-5	4×R8i + 2×BL-25-5	3460	4195	5509	2996	2832	4027	2719	3138	2118	76	51.1	8200
ACS880-907-5130A-5	6×R8i + 3×BL-25-5	5130	6220	8168	4443	4199	5971	4031	4653	3141	78	76.7	12300
Diode supply units (DSU), ACS880-307													
6-pulse diode													
ACS880-307-0080A-5+A003	D6D ¹⁾	80	98	137	69	66	94	63	78	53	62	1.4	720
ACS880-307-0170A-5+A003	D6D ¹⁾	173	212	297	150	143	203	137	170	114	62	2	720
ACS880-307-0330A-5+A003	D7D ¹⁾	327	400	561	283	270	384	260	320	216	62	3	1070
ACS880-307-0490A-5+A003	D7D ¹⁾	490	600	840	424	405	576	389	480	324	62	4.1	1070
ACS880-307-0650A-5+A003	D8D ¹⁾	653	800	1120	566	540	768	518	640	432	65	5.8	1430
ACS880-307-0980A-5+A003	D8D ¹⁾	980	1200	1680	849	810	1152	778	960	648	65	7.6	1430
ACS880-307-0650A-5+A018	D8T ²⁾	653	800	1120	566	540	768	518	598	404	72	4.6	1300
ACS880-307-0980A-5+A018	D8T ²⁾	980	1200	1680	849	810	1152	778	898	606	72	6.6	1300
ACS880-307-1210A-5+A018	2×D8T ²⁾	1215	1488	2083	1052	1004	1428	964	1113	751	74	9.2	2600
ACS880-307-1820A-5+A018	2×D8T ²⁾	1823	2232	3125	1579	1507	2143	1446	1670	1127	74	13.3	2600
ACS880-307-2730A-5+A018	3×D8T ²⁾	2734	3348	4687	2368	2260	3214	2170	2504	1690	76	19.9	3900
ACS880-307-3640A-5+A018	4×D8T ²⁾	3645	4464	6250	3157	3013	4285	2893	3339	2254	76	26.6	5200
ACS880-307-4560A-5+A018	5×D8T ²⁾	4557	5580	7812	3946	3767	5357	3616	4174	2817	77	33.3	6500
ACS880-307-5470A-5+A018	6×D8T ²⁾	5468	6696	9374	4735	4520	6428	4339	5009	3381	78	40	7800
12-pulse diode													
ACS880-307-0910A-5+A004+A018	2×D7T ³⁾	912	1116	1562	790	781	1071	750	835	584	74	8.4	1800
ACS880-307-1210A-5+A004+A018	2×D8T ³⁾	1215	1488	2083	1052	1042	1428	1000	1113	779	74	9.2	2600
ACS880-307-1820A-5+A004+A018	2×D8T ³⁾	1823	2232	3125	1579	1562	2143	1500	1670	1169	74	13.3	2600
ACS880-307-2430A-5+A004+A018	4×D8T ³⁾	2430	2976	4166	2104	2083	2857	2000	2226	1558	76	18.4	5200
ACS880-307-3640A-5+A004+A018	4×D8T ³⁾	3645	4464	6250	3157	3125	4285	3000	3339	2337	76	26.6	5200
ACS880-307-5470A-5+A004+A018	6×D8T ³⁾	5468	6696	9374	4735	4687	6428	4500	5009	3506	78	40	7800

¹⁾ +A003 6-pulse, uncontrolled diode bridge

²⁾ +A018 6-pulse, half controlled diode bridge

³⁾ +A004 12-pulse, DSU

Ratings, types and voltages

Inverter units, air-cooled, ACS880-107, 690 V

Inverter unit (INU), ACS880-107

$U_N = 690$ V (range 525 to 690 V). The power ratings are valid at nominal voltage 690 V (4 to 5600 kW).

Drive type	Frame size	Nominal ratings			Light overload use		Heavy-duty use		Noise level (dB(A))	Heat dissipation (kW)	Air flow (m ³ /h)
		I_N (A)	I_{max} (A)	P_N (kW)	I_{Ld} (A)	P_{Ld} (kW)	I_{Hd} (A)	P_{Hd} (kW)			
ACS880-107-007A3-7	R5i	7.3	9.5	5.5	6.9	5.5	5.6	4	62	0.22	280
ACS880-107-009A8-7	R5i	9.8	12.7	7.5	9.3	7.5	7.3	5.5	62	0.28	280
ACS880-107-014A2-7	R5i	14.2	18.5	11	13.5	11	9.8	7.5	62	0.4	280
ACS880-107-0018A-7	R5i	18	23.4	15	17.1	15	14.2	11	62	0.49	280
ACS880-107-0022A-7	R5i	22	29	18.5	20.9	18.5	18	15	62	0.58	280
ACS880-107-0027A-7	R5i	27	35	22	25.7	22	22	18.5	62	0.66	280
ACS880-107-0035A-7	R5i	35	46	30	33.3	30	27	22	62	0.86	280
ACS880-107-0042A-7	R5i	42	55	37	39.9	37	35	30	62	1	280
ACS880-107-0052A-7	R5i	52	68	45	49.4	45	42	37	62	1.12	280
ACS880-107-0062A-7	R6i	62	81	55	60	55	46	45	71	0.8	650
ACS880-107-0082A-7	R6i	82	107	75	79	75	61	55	71	1.1	650
ACS880-107-0100A-7	R6i	99	129	90	95	90	74	75	71	1.3	650
ACS880-107-0130A-7	R6i	125	163	110	120	110	94	75	71	1.5	650
ACS880-107-0140A-7	R6i	144	187	132	138	132	108	90	71	1.8	650
ACS880-107-0190A-7	R6i	192	250	160	184	160	144	132	71	2.5	650
ACS880-107-0220A-7	R7i	217	282	200	208	200	162	160	72	2.8	940
ACS880-107-0270A-7	R7i	270	351	250	259	250	202	200	72	3.3	940
ACS880-107-0340A-7	R8i	340	510	315	326	250	254	200	72	5.2	1300
ACS880-107-0410A-7	R8i	410	620	400	394	355	307	250	72	6.1	1300
ACS880-107-0530A-7	R8i	530	800	500	509	450	396	355	72	7.9	1300
ACS880-107-0600A-7	R8i	600	900	560	576	560	449	400	72	9	1300
ACS880-107-0800A-7	2×R8i	800	1200	800	768	710	598	560	74	12	2600
ACS880-107-1030A-7	2×R8i	1030	1550	1000	989	900	770	710	74	15	2600
ACS880-107-1170A-7	2×R8i	1170	1760	1100	1123	1000	875	800	74	18	2600
ACS880-107-1540A-7	3×R8i	1540	2310	1400	1478	1400	1152	1100	76	23	3900
ACS880-107-1740A-7	3×R8i	1740	2610	1600	1670	1600	1302	1200	76	26	3900
ACS880-107-2300A-7	4×R8i	2300	3450	2000	2208	2000	1720	1600	76	35	5200
ACS880-107-2860A-7	5×R8i	2860	4290	2800	2746	2400	2139	2000	77	43	6500
ACS880-107-3420A-7	6×R8i	3420	5130	3200	3283	3200	2558	2400	78	52	7800
ACS880-107-3990A-7	7×R8i	3990	5990	3600	3830	3600	2985	2800	78	60	9100
ACS880-107-4560A-7	8×R8i	4560	6840	4400	4378	4000	3411	3200	79	69	10400
ACS880-107-5130A-7	9×R8i	5130	7700	4800	4925	4800	3837	3600	79	78	11700
ACS880-107-5700A-7	10×R8i	5700	8550	5600	5472	5200	4264	4000	79	86	13000

Nominal ratings

I_N	Rated current available continuously without overloadability at 40 °C.
S_N	Nominal apparent power.
P_N	Typical motor power in no-overload use.

Maximum output current

I_{max}	Maximum output current. Available for 10 seconds at start, then as long as allowed by drive temperature.
-----------	--

Light-overload use

I_{Ld}	Continuous current allowing 110% I_{Ld} for 1 minute every 5 minutes at 40 °C.
P_{Ld}	Typical motor power in light-overload use.

Heavy-duty use

I_{Hd}	Continuous current allowing 150% I_{Hd} for 1 minute every 5 minutes at 40 °C.
P_{Hd}	Typical motor power in heavy-duty use.

The ratings apply at 40 °C ambient temperature. At higher temperatures (up to 50 °C) the derating is 1%/1 °C.

The current ratings are the same regardless of the supply voltage within one voltage range. Dimensioning has to be checked by DriveSize.

Ratings, types and voltages

Supply units, air-cooled, ACS880-x07, 690 V

Supply unit

$U_N = 690$ V (range 525 to 690 V)

Drive type	Frame size	Nominal ratings				No overload use	Light overload use		Heavy-duty use		Noise level (dB(A))	Heat dissipation (kW)	Air flow (m ³ /h)
		I_N AC (A)	I_N DC (A)	I_{max} DC (A)	S_N (kVA)	P_N DC (kW)	I_{Ld} DC (A)	P_{Ld} DC (kW)	I_{Hd} DC (A)	P_{Hd} DC (kW)			
IGBT supply units (ISU), ACS880-207													
ACS880-207-0310A-7	R8i + BLCL-13-7	306	371	557	366	362	356	348	278	271	72	8.7	2200
ACS880-207-0370A-7	R8i + BLCL-13-7	369	447	671	441	437	430	419	335	327	72	10.1	2200
ACS880-207-0540A-7	R8i + BLCL-15-7	540	655	982	645	639	629	613	490	478	72	14.6	2200
ACS880-207-0720A-7	2×R8i + BLCL-24-7	720	873	1309	860	852	838	818	653	637	74	18.4	4100
ACS880-207-1050A-7	2×R8i + BLCL-25-7	1053	1277	1915	1258	1246	1226	1196	955	932	74	27.9	4100
ACS880-207-1570A-7	3×R8i + 2×BLCL-24-7	1566	1899	2848	1872	1853	1823	1779	1420	1386	76	39.6	6900
ACS880-207-2070A-7	4×R8i + 2×BLCL-25-7	2070	2510	3765	2474	2449	2409	2351	1877	1832	76	55.9	8200
ACS880-207-3080A-7	6×R8i + 3×BLCL-25-7	3078	3732	5598	3679	3642	3583	3496	2792	2724	78	83.8	12300
ACS880-207-4100A-7	8×R8i + 4×BLCL-25-7	4104	4976	7464	4905	4856	4777	4661	3722	3632	79	111.7	16400
ACS880-207-5130A-7	10×R8i + 5×BLCL-25-7	5130	6220	9330	6131	6070	5971	5827	4653	4540	79	139.7	20500
Regenerative rectifier units (RRU), ACS880-907													
ACS880-907-0600A-7	R8i + BL-15-7	600	727	1102	717	678	698	651	544	507	72	9.8	2200
ACS880-907-0900A-7	R8i + BL-15-7	900	1 091	1653	1076	1016	1 048	976	816	760	72	14.3	2200
ACS880-907-1180A-7	2×R8i + BL-25-7	1180	1 431	2168	1410	1333	1 374	1 279	1 070	997	74	18.5	4100
ACS880-907-1770A-7	2×R8i + BL-25-7	1770	2 146	3252	2115	1999	2 060	1 919	1 605	1495	74	28.1	4100
ACS880-907-2310A-7	4×R8i + 2xBL-25-7	2310	2 801	4244	2761	2609	2 689	2 505	2 095	1952	76	37.1	8200
ACS880-907-3460A-7	4×R8i + 2xBL-25-7	3460	4 195	6356	4135	3908	4 027	3 752	3 138	2923	76	56.2	8200
ACS880-907-5130A-7	6×R8i + 3xBL-25-7	5130	6 220	9424	6131	5794	5 971	5562	4 653	4334	78	84.3	12300
Diode supply units (DSU), ACS880-307													
6-pulse diode													
ACS880-307-0570A-7+A018	D8T ¹⁾	572	700	980	684	652	672	626	524	488	72	4.5	1300
ACS880-307-0820A-7+A018	D8T ¹⁾	817	1000	1400	976	932	960	894	748	697	72	5.8	1300
ACS880-307-1060A-7+A018	2×D8T ¹⁾	1064	1302	1823	1272	1213	1250	1164	974	907	74	9	2600
ACS880-307-1520A-7+A018	2×D8T ¹⁾	1519	1860	2604	1815	1733	1786	1663	1391	1296	74	12.7	2600
ACS880-307-2280A-7+A018	3×D8T ¹⁾	2279	2790	3906	2724	2599	2678	2495	2087	1944	76	19.1	3900
ACS880-307-3040A-7+A018	4×D8T ¹⁾	3038	3720	5208	3631	3465	3571	3327	2783	2592	76	25.5	5200
ACS880-307-3800A-7+A018	5×D8T ¹⁾	3797	4650	6510	4538	4331	4464	4158	3478	3240	77	32	6500
ACS880-307-4560A-7+A018	6×D8T ¹⁾	4557	5580	7812	5446	5198	5357	4990	4174	3888	78	38.4	7800
12-pulse diode													
ACS880-307-0760A-7+A004+A018	2×D7T ²⁾	760	930	1302	908	898	893	862	696	672	74	7.7	1800
ACS880-307-1060A-7+A004+A018	2×D8T ²⁾	1064	1302	1823	1272	1258	1250	1207	974	941	74	9	2600
ACS880-307-1520A-7+A004+A018	2×D8T ²⁾	1519	1860	2604	1815	1797	1786	1725	1391	1344	74	12.7	2600
ACS880-307-2130A-7+A004+A018	4×D8T ²⁾	2127	2604	3646	2542	2515	2500	2415	1948	1882	76	18.1	5200
ACS880-307-3040A-7+A004+A018	4×D8T ²⁾	3038	3720	5208	3631	3594	3571	3450	2783	2688	76	25.5	5200
ACS880-307-4560A-7+A004+A018	6×D8T ²⁾	4557	5580	7812	5446	5390	5357	5175	4174	4032	78	38.4	7800

¹⁾ +A018 6-pulse, half controlled diode bridge

²⁾ +A004 12-pulse, DSU

Ratings, types and voltages

DC/DC converter, air-cooled, ACS880-1607

$U_N = 400$ V (range 380 to 415 V). The power ratings are valid at nominal voltage 400 V.

Converter type	Frame size	No-overload use					Short time overload cycle (10 s/60 s)		Heavy overload cycle (1 min/5 min)		Noise level (dB(A))	Heat dissipation (kW)	Air flow (m ³ /h)	Filter type
		I_{dc} input (A)	I_{rms} output (A)	$P_{contmax}$ (kW)	I_{max} output (A)	I_{p2p} (A)	I_{short} time (A)	P_{short} time (kW)	I_{Hd} (A)	P_{Hd} (kW)				
ACS880-1607-0600A-3	R8i 600	600	600	305	900	22	450	229	510	260	74	5.2	2200	BDCL-14-5
ACS880-1607-0900A-3	R8i 900	900	900	458	1350	33	675	343	765	389	74	8	2200	BDCL-15-5
ACS880-1607-1200A-3	2xR8i 1200	1200	1200	611	1800	11	899	458	1020	519	76	10.5	4400	2xBDCL-14-5
ACS880-1607-1800A-3	2xR8i 1800	1800	1800	916	2700	16	1349	687	1529	779	76	10.5	4400	2xBDCL-15-5

$U_N = 500$ V (range 380 to 500 V). The power ratings are valid at nominal voltage 500 V.

Converter type	Frame size	No-overload use					Short time overload cycle (10 s/60 s)		Heavy overload cycle (1 min/5 min)		Noise level (dB(A))	Heat dissipation (kW)	Air flow (m ³ /h)	Filter type
		I_{dc} input (A)	I_{rms} output (A)	$P_{contmax}$ (kW)	I_{max} output (A)	I_{p2p} (A)	I_{short} time (A)	P_{short} time (kW)	I_{Hd} (A)	P_{Hd} (kW)				
ACS880-1607-0600A-5	R8i 600	600	600	382	900	27	450	286	510	324	74	6	2200	BDCL-14-5
ACS880-1607-0900A-5	R8i 900	900	900	573	1350	41	675	429	765	487	74	9.1	2200	BDCL-15-5
ACS880-1607-1200A-5	2xR8i 1200	1200	1200	764	1800	14	899	572	1020	649	76	12.1	4400	2xBDCL-14-5
ACS880-1607-1800A-5	2xR8i 1800	1800	1800	1146	2700	20	1349	859	1529	973	76	18.8	4400	2xBDCL-15-5

$U_N = 690$ V (range 525 to 690 V). The power ratings are valid at nominal voltage 690 V.

Converter type	Frame size	No-overload use					Short time overload cycle (10 s/60 s)		Heavy overload cycle (1 min/5 min)		Noise level (dB(A))	Heat dissipation (kW)	Air flow (m ³ /h)	Filter type
		I_{dc} input (A)	I_{rms} output (A)	$P_{contmax}$ (kW)	I_{max} output (A)	I_{p2p} (A)	I_{short} time (A)	P_{short} time (kW)	I_{Hd} (A)	P_{Hd} (kW)				
ACS880-1607-0400A-7	R8i 400	400	400	351	600	38	300	263	340	298	74	6.4	2200	BDCL-14-7
ACS880-1607-0600A-7	R8i 600	600	600	527	900	56	450	395	510	448	74	10.6	2200	BDCL-15-7
ACS880-1607-0800A-7	2xR8i 800	800	800	703	1200	19	600	527	680	597	76	12.8	4400	2xBDCL-14-7
ACS880-1607-1200A-7	2xR8i 1200	1200	1200	1054	1800	28	899	790	1020	895	76	21.5	4400	2xBDCL-15-7

No overload use

I_{dc} input	Maximum continuous input DC current from DC bus
I_{rms} output	Maximum continuous output current to/from energy storage
$P_{contmax}$	Maximum continuous output power to/from energy storage
I_{max} output	Maximum instantaneous output current to/from energy storage
I_{p2p}	Maximum output ripple current to/from energy storage

Short time / heavy overload cycle

I_{short} time	Continuous output current allowing 10 s of I_{max} (DC) every 60 seconds
P_{short} time	Continuous output power allowing 10 s of I_{max} (DC) every 60 seconds
I_{Hd}	Continuous output current allowing overload of 150% I_{hd} for 1 min every 5 min
P_{Hd}	Continuous output power allowing 150% I_{hd} for 1 min every 5 min

Several DC/DC converters can be connected to achieve higher power ratings.

Ratings, types and voltages

Inverter units, liquid-cooled, ACS880-107LC, 500 V

$U_N = 500$ V (range 380 to 500 V). The power ratings are valid at nominal voltage 500 V (45 to 315 kW).

Inverter module type	Frame size	Nominal ratings			Light overload use		Heavy-duty use		Noise level ¹⁾ (dB(A))	Losses P_{loss} (kW)	Coolant flow rate (l/min)
		I_N (A)	I_{max} (A)	P_N (kW)	I_{Ld} (A)	P_{Ld} (kW)	I_{Hd} (A)	P_{Hd} (kW)			
Liquid-cooled inverter units (INU). ACS880-107LC											
ACS880-107LC-0094A-5	R7i	94	150	55	90	55	70	45	63	1.0	13
ACS880-107LC-0120A-5	R7i	115	180	75	110	75	86	55	63	1.2	13
ACS880-107LC-0140A-5	R7i	140	210	90	134	90	105	55	63	1.5	13
ACS880-107LC-0170A-5	R7i	170	260	110	163	110	127	75	63	1.7	13
ACS880-107LC-0200A-5	R7i	200	300	132	192	132	150	90	63	2.0	13
ACS880-107LC-0240A-5	R7i	240	360	160	230	160	180	110	63	2.5	13
ACS880-107LC-0300A-5	R7i	302	460	200	290	200	226	132	63	3.3	13
ACS880-107LC-0380A-5	R7i	380	570	250	365	200	284	160	63	4.7	13
ACS880-107LC-0460A-5	R7i	461	700	315	443	315	345	200	63	6.15	13

Nominal ratings

I_N	Rated current available continuously without overloadability
P_N	Typical motor power in no-overload use
S_N	Nominal apparent (AC) power

Maximum output current

I_{max}	Maximum output current. Available for 10 seconds at start, then as long as allowed by module temperature.
-----------	---

Light-overload use

I_{Ld}	Continuous current allowing 110% I_{Ld} for 1 minute every 5 minutes.
P_{Ld}	Typical motor power in light-overload use.

Heavy-duty use

I_{Hd}	Continuous current allowing 150% I_{Hd} for 1 minute every 5 minutes
P_{Hd}	Typical motor power in heavy-duty use.

Losses

P_{loss}	Power loss conducted to coolant and emitted to air
------------	--

The ratings apply at an ambient air temperature of 45 °C and a coolant temperature of 40 °C.

Ratings, types and voltages

Supply units, liquid-cooled, ACS880-207LC, 500 V

$U_N = 500$ V (range 380 to 500 V). The power ratings are valid at nominal voltage 500 V (174 to 359 kVA).

Supply module type	Frame size	Nominal ratings					Light overload use		Heavy-duty use		Noise level ¹⁾ (dB(A))	Losses ²⁾ P_{loss} (kW)	Coolant flow rate ³⁾ (l/min)
		I_N AC (A)	I_N DC (A)	I_{max} DC (A)	S_N (kVA)	P_N DC (kW)	I_{Ld} DC (A)	P_{Ld} DC (kW)	I_{Hd} DC (A)	P_{Hd} DC (kW)			
Liquid-cooled supply units (ISU), ACS880-107LC													
ACS880-207LC-0270A-5	R7i	272	330	494	235	233	316	224	247	174	66	5.8	38
ACS880-207LC-0340A-5	R7i	342	415	622	296	293	398	281	310	219	66	7.3	38
ACS880-207LC-0410A-5	R7i	415	503	755	359	356	483	341	376	266	66	9.0	38

¹⁾ Noise level in a typical cabinet installation.

²⁾ Losses for the whole supply unit (ACU + ICU + ISU + filter). In totally enclosed cabinet 98% of losses are conducted to coolant, 2% to ambient air.

³⁾ Coolant flow rate for the whole supply unit (ACU + ICU + ISU + filter).

Nominal ratings

I_N	Rated current available continuously without overloadability
P_N	Typical motor power in no-overload use
S_N	Nominal apparent (AC) power

Maximum output current

I_{max}	Maximum output current. Available for 10 seconds at start, then as long as allowed by module temperature.
-----------	---

Light-overload use

I_{Ld}	Continuous current allowing 110% I_{Ld} for 1 minute every 5 minutes.
P_{Ld}	Typical motor power in light-overload use.

Heavy-duty use

I_{Hd}	Continuous current allowing 150% I_{Hd} for 1 minute every 5 minutes
P_{Hd}	Typical motor power in heavy-duty use.

Losses

P_{loss}	Power loss conducted to coolant and emitted to air
------------	--

The ratings apply at an ambient air temperature of 45 °C and a coolant temperature of 40 °C.

Ratings, types and voltages

Inverter units, liquid-cooled, ACS880-107LC, 690 V

$U_N = 690$ V (range 525 to 690 V). The power ratings are valid at nominal voltage 690 V (55 to 6000 kW).

Inverter module type	Frame size	Nominal ratings			Light overload use		Heavy-duty use		Noise level ¹⁾ (dB(A))	Losses P_{loss} (kW)	Coolant flow rate (l/min)
		I_N (A)	I_{max} (A)	P_N (kW)	I_{Ld} (A)	P_{Ld} (kW)	I_{Hd} (A)	P_{Hd} (kW)			
Liquid-cooled inverter units (INU), ACS880-107LC											
ACS880-107LC-0062A-7	R7i	62	105	55	60	55	46	45	63	1.1	13
ACS880-107LC-0082A-7	R7i	82	146	75	79	75	61	55	63	1.3	13
ACS880-107LC-0100A-7	R7i	99	169	90	95	90	74	75	63	1.5	13
ACS880-107LC-0130A-7	R7i	125	214	110	120	110	94	75	63	1.9	13
ACS880-107LC-0140A-7	R7i	144	248	132	138	132	108	90	63	2.2	13
ACS880-107LC-0190A-7	R7i	192	326	160	184	160	144	132	63	3.2	13
ACS880-107LC-0220A-7	R7i	217	371	200	208	200	162	160	63	3.7	13
ACS880-107LC-0290A-7	R7i	289	495	250	277	250	216	200	63	4.5	13
ACS880-107LC-0340A-7	R7i	340	574	315	326	250	254	200	63	5.6	13
ACS880-107LC-0389A-7	R7i	390	664	355	374	355	292	250	63	6.7	13
ACS880-107LC-0390A-7	R8i	390	590	355	374	355	292	250	63	5.1	16
ACS880-107LC-0430A-7	R8i	430	650	400	413	355	322	250	63	5.6	16
ACS880-107LC-0480A-7	R8i	480	720	450	461	400	359	315	63	6.4	16
ACS880-107LC-0530A-7	R8i	530	800	500	509	450	396	355	63	7.2	16
ACS880-107LC-0600A-7	R8i	600	900	560	576	560	449	400	63	8.2	16
ACS880-107LC-0670A-7	R8i	670	1010	630	643	630	501	450	63	9.4	16
ACS880-107LC-0750A-7	R8i	750	1130	710	720	710	561	500	63	10.8	16
ACS880-107LC-0850A-7	R8i	850	1280	800	816	800	636	560	63	12.7	16
ACS880-107LC-1030A-7	2×R8i	1030	1550	1000	989	900	770	710	66	14	32
ACS880-107LC-1170A-7	2×R8i	1170	1760	1100	1123	1100	875	800	66	16	32
ACS880-107LC-1310A-7	2×R8i	1310	1970	1200	1258	1200	980	900	66	18.4	32
ACS880-107LC-1470A-7	2×R8i	1470	2210	1400	1411	1200	1100	1000	66	21.2	32
ACS880-107LC-1660A-7	2×R8i	1660	2490	1600	1594	1400	1242	1200	66	24.8	32
ACS880-107LC-1940A-7	3×R8i	1940	2910	1800	1862	1800	1451	1400	68	27.2	48
ACS880-107LC-2180A-7	3×R8i	2180	3270	2000	2093	2000	1631	1400	68	31.4	48
ACS880-107LC-2470A-7	3×R8i	2470	3710	2300	2371	2300	1848	1800	68	36.9	48
ACS880-107LC-2880A-7	4×R8i	2880	4320	2700	2765	2700	2154	2000	69	41.5	64
ACS880-107LC-3260A-7	4×R8i	3260	4890	3000	3130	3000	2438	2300	69	48.7	64
ACS880-107LC-3580A-7	5×R8i	3580	5370	3400	3437	3200	2678	2600	70	51.6	80
ACS880-107LC-4050A-7	5×R8i	4050	6080	3800	3888	3800	3029	2800	70	60.5	80
ACS880-107LC-4840A-7	6×R8i	4840	7260	4400	4646	4400	3620	3500	71	72.3	96
ACS880-107LC-5650A-7	7×R8i	5650	8480	5200	5424	5200	4226	4000	72	84.4	112
ACS880-107LC-6460A-7	8×R8i	6460	9690	6000	6202	6000	4832	4700	72	96.5	128

Nominal ratings

I_N Rated current available continuously without overloadability

P_N Typical motor power in no-overload use

S_N Nominal apparent (AC) power

Maximum output current

I_{max} Maximum output current. Available for 10 seconds at start, then as long as allowed by module temperature.

Light-overload use

I_{Ld} Continuous current allowing 110% I_{Ld} for 1 minute every 5 minutes.

P_{Ld} Typical motor power in light-overload use.

Heavy-duty use

I_{Hd} Continuous current allowing 150% I_{Hd} for 1 minute every 5 minutes

P_{Hd} Typical motor power in heavy-duty use.

Losses

P_{loss} Power loss conducted to coolant and emitted to air

The ratings apply at an ambient air temperature of 45 °C and a coolant temperature of 40 °C.

Ratings, types and voltages

Supply units, liquid-cooled, ACS880-207LC, 690 V

$U_N = 690$ V (range 525 to 690 V). The power ratings are valid at nominal voltage 690 V (430 to 6944 kVA).

Supply module type	Frame size	Nominal ratings					Light overload use		Heavy-duty use		Noise level ¹⁾ (dB(A))	Losses ²⁾ P_{loss} (kW)	Coolant flow rate ³⁾ (l/min)
		I_N AC (A)	I_N DC (A)	I_{max} DC (A)	S_N (kVA)	P_N DC (kW)	I_{Ld} DC (A)	P_{Ld} DC (kW)	I_{Hd} DC (A)	P_{Hd} DC (kW)			
Liquid-cooled IGBT supply units (ISU), ACS880-207LC													
ACS880-207LC-0260A-7	R7i	260	315	473	311	308	303	295	236	230	66	7.8	36
ACS880-207LC-0310A-7	R7i	306	371	557	366	362	356	348	278	271	66	9.2	36
ACS880-207LC-0350A-7	R7i	351	426	638	419	415	409	399	318	311	66	10.9	36
ACS880-207LC-0360A-7	R8i	360	436	655	430	426	419	409	327	319	66	9.1	52
ACS880-207LC-0400A-7	R8i	400	485	727	478	473	466	454	363	354	66	10.1	52
ACS880-207LC-0450A-7	R8i	450	546	818	538	532	524	511	408	398	66	11.4	52
ACS880-207LC-0480A-7	R8i	480	582	873	574	568	559	545	435	425	66	12.3	52
ACS880-207LC-0560A-7	R8i	560	679	1018	669	663	652	636	508	496	66	14.5	52
ACS880-207LC-0620A-7	R8i	620	752	1128	741	734	722	704	562	549	66	16.1	52
ACS880-207LC-0700A-7	R8i	700	849	1273	837	828	815	795	635	620	66	18.8	52
ACS880-207LC-0770A-7	R8i	770	934	1400	920	911	896	875	698	681	66	21.4	52
ACS880-207LC-0930A-7	2×R8i	930	1128	1691	1111	1100	1083	1056	843	823	68	21.8	88
ACS880-207LC-1090A-7	2×R8i	1090	1322	1982	1303	1290	1269	1238	989	965	68	25.9	88
ACS880-207LC-1180A-7	2×R8i	1180	1431	2146	1410	1396	1374	1340	1070	1044	68	29.4	88
ACS880-207LC-1360A-7	2×R8i	1360	1649	2473	1625	1609	1583	1545	1233	1204	68	31.8	88
ACS880-207LC-1500A-7	2×R8i	1500	1819	2728	1793	1775	1746	1704	1360	1328	68	36	88
ACS880-207LC-1800A-7	3×R8i	1800	2182	3274	2151	2130	2095	2045	1633	1593	70	40.3	144
ACS880-207LC-2020A-7	3×R8i	2020	2449	3674	2414	2390	2351	2294	1832	1788	70	46.8	144
ACS880-207LC-2220A-7	3×R8i	2220	2692	4038	2653	2627	2584	2522	2013	1965	70	53	144
ACS880-207LC-2670A-7	4×R8i	2670	3237	4856	3191	3159	3108	3033	2422	2363	71	60.1	160
ACS880-207LC-2930A-7	4×R8i	2930	3553	5329	3502	3467	3411	3328	2657	2593	71	67.9	160
ACS880-207LC-3320A-7	5×R8i	3320	4025	6038	3968	3928	3864	3771	3011	2938	72	75.7	216
ACS880-207LC-3840A-7	6×R8i	3840	4656	6984	4589	4543	4470	4362	3483	3398	73	86	280
ACS880-207LC-4360A-7	6×R8i	4360	5286	7930	5211	5159	5075	4952	3954	3859	73	103.2	280
ACS880-207LC-5240A-7	8×R8i	5240	6353	9530	6262	6200	6099	5952	4752	4637	74	116.8	312
ACS880-207LC-5810A-7	8×R8i	5810	7045	10567	6944	6874	6763	6599	5269	5142	74	133.7	312

¹⁾ Noise level in a typical cabinet installation.

²⁾ Losses for the whole supply unit (ACU + ICU + ISU + filter). In totally enclosed cabinet 98% of losses are conducted to coolant, 2% to ambient air.

³⁾ Coolant flow rate for the whole supply unit (ACU + ICU + ISU + filter).

Nominal ratings

I_N Rated current available continuously without overloadability

P_N Typical motor power in no-overload use

S_N Nominal apparent (AC) power

Maximum output current

I_{max} Maximum output current. Available for 10 seconds at start, then as long as allowed by module temperature.

Light-overload use

I_{Ld} Continuous current allowing 110% I_{Ld} for 1 minute every 5 minutes.

P_{Ld} Typical motor power in light-overload use.

Heavy-duty use

I_{Hd} Continuous current allowing 150% I_{Hd} for 1 minute every 5 minutes

P_{Hd} Typical motor power in heavy-duty use.

Losses

P_{loss} Power loss conducted to coolant and emitted to air

The ratings apply at an ambient air temperature of 45 °C and a coolant temperature of 40 °C.

Ratings, types and voltages

Supply units, liquid-cooled, ACS880-307LC, 690 V

$U_N = 690$ V (range 525 to 690 V). The power ratings are valid at nominal voltage 690 V (366 to 5446 kVA).

Supply module type	Frame size	Nominal ratings					Light overload use		Heavy-duty use		Noise level (dB(A))	Losses ¹⁾ P_{loss} (kW)	Coolant flow rate ²⁾ (l/min)
		I_N AC (A)	I_N DC (A)	I_{max} DC (A)	S_N (kVA)	P_N DC (kW)	I_{Ld} DC (A)	P_{Ld} DC (kW)	I_{Hd} DC (A)	P_{Hd} DC (kW)			
Liquid-cooled diode supply units (DSU), ACS880-304LC													
6-pulse diode													
ACS880-307LC-0490A-7+A018 ¹⁾	D8T	490	600	900	585	559	576	537	449	418	65	3.0	14
ACS880-307LC-0780A-7+A018 ¹⁾	D8T	780	955	1430	932	890	917	854	714	666	65	4.6	14
ACS880-307LC-1060A-7+A018 ¹⁾	D8T	1060	1300	1950	1267	1211	1248	1163	972	906	65	6.2	14
ACS880-307LC-1470A-7+A018 ¹⁾	2×D8T	1470	1800	2700	1757	1677	1728	1610	1346	1255	65	8.7	28
ACS880-307LC-2000A-7+A018 ¹⁾	2×D8T	2000	2450	3675	2390	2283	2352	2192	1833	1708	65	11.7	28
ACS880-307LC-3000A-7+A018 ¹⁾	3×D8T	3000	3670	5505	3585	3420	3523	3283	2745	2558	67	17.5	42
ACS880-307LC-4000A-7+A018 ¹⁾	4×D8T	4000	4900	7350	4780	4566	4704	4383	3665	3415	67	23.4	56
12-pulse diode													
ACS880-307LC-0920A-7+A004+A018 ²⁾	2×D8T	920	1130	1695	1100	1053	1085	1011	845	788	67	5.6	28
ACS880-307LC-1470A-7+A004+A018 ²⁾	2×D8T	1470	1800	2700	1757	1677	1728	1610	1346	1255	67	8.7	28
ACS880-307LC-2000A-7+A004+A018 ²⁾	2×D8T	2000	2450	3675	2390	2283	2352	2192	1833	1708	67	11.7	28
ACS880-307LC-2940A-7+A004+A018 ²⁾	4×D8T	2940	3600	5400	3514	3355	3456	3220	2693	2509	68	18.0	56
ACS880-307LC-4000A-7+A004+A018 ²⁾	4×D8T	4000	4900	7350	4780	4566	4704	4383	3665	3415	68	23.4	56

¹⁾ +A018 is option code for half controlled diode bridge.

²⁾ +A004 is 12-pulse DSU.

Nominal ratings

I_N	Rated current available continuously without overloadability
P_N	Typical motor power in no-overload use
S_N	Nominal apparent (AC) power

Maximum output current

I_{max}	Maximum output current. Available for 10 seconds at start, then as long as allowed by module temperature.
-----------	---

Light-overload use

I_{Ld}	Continuous current allowing 110% I_{Ld} for 1 minute every 5 minutes.
P_{Ld}	Typical motor power in light-overload use.

Heavy-duty use

I_{Hd}	Continuous current allowing 150% I_{Hd} for 1 minute every 5 minutes
P_{Hd}	Typical motor power in heavy-duty use.

Losses

P_{loss}	Power loss conducted to coolant and emitted to air
------------	--

The ratings apply at an ambient air temperature of 45 °C and a coolant temperature of 40 °C.

Ratings, types and voltages

Liquid cooling unit, ACS880-1007LC

Range 380 to 690 V

Liquid-cooling unit type	Nominal ratings			Noise level (dB(A))	Losses				Internal flow ¹⁾ (l/min)	External flow ²⁾ (l/min)
	P_{\max} (kW)	Internal coolant volume (l)	External coolant volume (l)		$P_{\text{loss total}}$ (kW)	$P_{\text{loss coolant}}$ (kW)	$P_{\text{loss air}}$ (kW)	P_{drop} (kPa)		
ACS880-1007LC-0070 ³⁾	70	17	3	55	0.4	0.3	0.1	150	81/107	120
ACS880-1007LC-0195+C140 ³⁾ /C141 ⁴⁾	195	31/35	8	55	1.3	1.0	0.3	150	270/355	467
ACS880-1007LC-0195+C213 ⁵⁾	195	35	8	57	2.1	1.8	0.3	150	310/415	467

¹⁾ 120 kPa, Antifrogen® L 25%, 40 °C, 50/60 Hz

²⁾ 36 °C water

³⁾ Single pump

⁴⁾ Redundant, one pump running at a time

⁵⁾ Redundant, two pumps running at a time

Nominal ratings

P_{\max}	Maximum nominal cooling power
Internal flow	Nominal coolant flow rate from the liquid cooling unit to the drive modules
External flow	Nominal coolant flow rate to the liquid cooling unit from an external cooling circuit

Losses

$P_{\text{loss total}}$	Power loss conducted to coolant and emitted to air
$P_{\text{loss coolant}}$	Power loss conducted to coolant
$P_{\text{loss air}}$	Power loss emitted to air (ambient room)
P_{drop}	Pressure loss in external cooling unit

Ratings, types and voltages

DC/DC converter, liquid-cooled, ACS880-1607LC

$U_N = 500\text{ V}$ (range 380 to 500 V). The power ratings are valid at nominal voltage 500 V.

Converter type	Frame size	No overload use					Short time overload cycle (10 s/60 s)		Heavy overload cycle (1 min/5 min)		Noise level (dB(A))	Losses P_{loss} (kW)	Coolant flow rate ¹⁾ (l/min)	Filter type
		$I_{\text{dc input DC}}$ (A)	$I_{\text{rms output DC}}$ (A)	P_{contmax} (kW)	$I_{\text{max output DC}}$ (A)	I_{p2p} (A)	$I_{\text{short time}}$ (A)	$P_{\text{short time}}$ (kW)	I_{Hd} (A)	P_{Hd} (kW)				
ACS880-1607LC-0150A-5	R7iLC	147	150	95	188	9	94	60	113	72	64	1.1	15	BDCL-13LC-7
ACS880-1607LC-0250A-5	R7iLC	244	250	159	313	9	156	99	189	120	64	1.6	15	BDCL-13LC-7
ACS880-1607LC-0350A-5	R7iLC	341	350	223	438	9	219	139	265	168	64	2.1	15	BDCL-13LC-7
ACS880-1607LC-0450A-5	R7iLC	439	450	286	563	9	281	179	340	216	64	2.8	15	BDCL-13LC-7
ACS880-1607LC-0550A-5	R7iLC	536	550	350	688	9	344	219	416	265	64	3.5	15	BDCL-13LC-7
ACS880-1607LC-0700A-5	2xR7iLC	682	700	446	875	5	437	278	529	337	66	4.1	30	2xBDCL-13LC-7
ACS880-1607LC-0900A-5	2xR7iLC	876	900	572	1125	5	562	358	680	433	66	5.4	30	2xBDCL-13LC-7
ACS880-1607LC-1100A-5	2xR7iLC	1071	1100	700	1375	5	687	437	831	529	66	6.7	30	2xBDCL-13LC-7

¹⁾ Coolant flow rate for the whole converter unit (DC/DC converter module and filter).

$U_N = 690\text{ V}$ (range 525 to 690 V). The power ratings are valid at nominal voltage 690 V.

Converter type	Frame size	No overload use					Short time overload cycle (10 s/60 s)		Heavy overload cycle (1 min/5 min)		Noise level (dB(A))	Losses P_{loss} (kW)	Coolant flow rate ¹⁾ (l/min)	Filter type
		$I_{\text{dc input DC}}$ (A)	$I_{\text{rms output DC}}$ (A)	P_{contmax} (kW)	$I_{\text{max output DC}}$ (A)	I_{p2p} (A)	$I_{\text{short time}}$ (A)	$P_{\text{short time}}$ (kW)	I_{Hd} (A)	P_{Hd} (kW)				
ACS880-1607LC-0400A-7	R8i	391	400	351	500	38	250	219	302	266	64	4.2	36	BDCL-14LC-7
ACS880-1607LC-0500A-7	R8i	490	500	439	625	38	312	274	378	332	64	5.3	36	BDCL-14LC-7
ACS880-1607LC-0600A-7	R8i	590	600	527	750	56	375	329	453	398	64	6.2	36	BDCL-15LC-7
ACS880-1607LC-0700A-7	R8i	690	700	615	875	56	437	384	529	465	64	7.3	36	BDCL-15LC-7
ACS880-1607LC-0800A-7	R8i	790	800	703	1000	56	500	439	605	531	64	8.5	36	BDCL-15LC-7
ACS880-1607LC-0900A-7	R8i	880	900	790	1125	56	562	494	680	597	64	9.7	36	BDCL-15LC-7
ACS880-1607LC-1000A-7	2xR8i	980	1000	878	1250	19	625	549	756	664	66	11.2	72	2xBDCL-14LC-7
ACS880-1607LC-1200A-7	2xR8i	1180	1200	1054	1500	28	750	658	907	797	66	13.6	72	2xBDCL-15LC-7
ACS880-1607LC-1400A-7	2xR8i	1370	1400	1230	1750	28	874	768	1058	929	66	16.3	72	2xBDCL-15LC-7
ACS880-1607LC-1600A-7	2xR8i	1570	1600	1405	2000	28	999	878	1209	1062	66	19	72	2xBDCL-15LC-7
ACS880-1607LC-1800A-7	2xR8i	1760	1800	1581	2250	28	1124	987	1360	1195	66	22	72	2xBDCL-15LC-7

Several DC/DC converters can be connected to achieve higher power ratings.

¹⁾ Coolant flow rate for the whole converter unit (DC/DC converter module and filter).

Ratings

No overload use

$I_{\text{dc input}}$	Maximum continuous input DC current from DC bus
$I_{\text{rms output}}$	Maximum continuous output current to/from energy storage
P_{contmax}	Maximum continuous output power to/from energy storage
$I_{\text{max output}}$	Maximum instantaneous output current to/from energy storage
I_{p2p}	Maximum output ripple current to/from energy storage

Short time / heavy overload cycle

$I_{\text{short time}}$	Continuous output current allowing 10 s of I_{max} (DC) every 60 seconds
$P_{\text{short time}}$	Continuous output power allowing 10 s of I_{max} (DC) every 60 seconds
I_{Hd}	Continuous output current allowing overload of 150% I_{hd} for 1 min every 5 min
P_{Hd}	Continuous output power allowing 150% I_{hd} for 1 min every 5 min

Losses

P_{loss}	Power loss conducted to coolant and emitted to air
-------------------	--

Dimensions

ACS880 air-cooled multidrives

Frame size		Height (mm)	Width (mm)	Depth (mm)	Weight (kg)
ACS880-207 IGBT supply unit (ISU).					
Dimensions include ACU, ICU, ISU and filter.					
R8i+BLCL-13-5	Limited scope ¹⁾	2145	1000	636	810
	Standard scope ¹⁾	2145	1600	636	1300
R8i+BLCL-15-5	Limited scope ¹⁾	2145	1000	636	860
	Standard scope ¹⁾	2145	1600	636	1300
2×R8i+BLCL-24-5	1040A-5	2145	1800	636	1600
	1130A-3, 1330A-3	2145	2000	636	1720
2×R8i+BLCL-25-5		2145	2000	636	1720
3×R8i+2×BLCL-24-5		2145	2600	636	2410
4×R8i+2×BLCL-25-5		2145	2800	636	2820
6×R8i+3×BLCL-25-5		2145	4000	636	3960
R8i+BLCL-13-7		2145	1600	636	1300
R8i+BLCL-15-7		2145	1600	636	1300
2×R8i+BLCL-24-7		2145	1800	636	1600
2×R8i+BLCL-25-7		2145	1800	636	1600
3×R8i+2×BLCL-25-7		2145	2600	636	2210
4×R8i+2×BLCL-25-7		2145	2800	636	2820
6×R8i+3×BLCL-25-7		2145	3600	636	3720
8×R8i+4×BLCL-25-7		2145	5100	636	4860
10×R8i+5×BLCL-25-7		2145	5900	636	5760
ACS880-907 regenerative rectifier unit (RRU).					
Dimensions include ACU, ICU, RRU and filter.					
1×R8i+BL-15-5		2145	1600	636	1275
2×R8i+BL-25-5		2145	2000	636	1615
4×R8i+2×BL-25-5	2310A-3/5	2145	2800	636	2610
	3460A-3/5	2145	3200	636	2850
6×R8i+3×BL-25-5		2145	4000	636	3645
1×R8i+BL-15-7		2145	1600	636	1275
2×R8i+BL-25-7		2145	2000	636	1615
4×R8i+2×BL-25-7	2310A-7	2145	2800	636	2610
	3460A-7	2145	3200	636	2850
6×R8i+3×BL-25-7		2145	4000	636	3645

¹⁾ In addition to standard ACS880 multidrive offering, limited scope offering is available with special configuration for 400 V and 500 V, R1i to R7i inverters.

²⁾ 2315 mm for IP54 and 2051 mm for IPxxR.

An additional 10 mm required for marine supports.

³⁾ Width and weight depend on the amount of inverter units.

With option own compartment (+C204) 400 mm for max. 3 inverters.

⁴⁾ Top exit with backpack for R1i to R7i, additional depth is 130 mm.

⁵⁾ Width and weight depend on the amount of inverter units.

With option own compartment (+C204) 500 mm for max. 2 R5i inverters.

⁶⁾ 300 mm is required for drive control unit (DCU).

One DCU can be used for two drive units.

⁷⁾ Top exit with backpack for n×R8i, additional depth is 190 mm.

⁸⁾ 2315 mm for IP54, and 2051 mm for IPXXR

⁹⁾ It is possible to connect multiple DC/DC converter units in parallel. Please see hardware manual (doc no 3AXD50000023644) for more detailed information.

¹⁰⁾ Please see hardware manual for further details.

Frame size		Height (mm)	Width (mm)	Depth (mm)	Weight (kg)
ACS880-307 diode supply unit (DSU).					
Dimensions include ACU, ICU and DSU.					
6-pulse diode					
D6D		2145	400	636	300
D7D		2145	400	636	350
D8D		2145	700	636	550
D8T		2145	1400	636	850
2×D8T	1060A-7	2145	1400	636	1130
	1210A-3/5, 1820A-3/5, 1520A-7	2145	1600	636	1130
3×D8T		2145	2000	636	1560
4×D8T	690 V drives	2145	2400	636	1940
	400/500 V drives	2145	2800	636	2140
5×D8T		2145	3000	636	2420
6×D8T		2145	3200	636	2700
12-pulse diode					
2×D7T		2145	1800	636	900
2×D8T		2145	1800	636	1180
4×D8T	2430A-3/5, 2130A-7	2145	2400	636	1840
	3640A-3, 3650A-5 3040A-7	2145	3000	636	2040
6×D8T		2145	3400	636	2900
ACS880-107 inverter unit (INU)					
R1i		2145 ²⁾	400 to 1000 ³⁾	636 ⁴⁾	240 to 490 ³⁾
R2i		2145 ²⁾	400 to 1000 ³⁾	636 ⁴⁾	240 to 490 ³⁾
R3i		2145 ²⁾	400 to 1000 ³⁾	636 ⁴⁾	240 to 490 ³⁾
R4i		2145 ²⁾	400 to 1000 ³⁾	636 ⁴⁾	240 to 490 ³⁾
R5i		2145 ²⁾	300 to 500 ⁵⁾	636	200 to 320 ⁵⁾
R6i		2145 ²⁾	400	636 ⁴⁾	250
R7i		2145 ²⁾	400	636 ⁴⁾	250
R8i		2145 ²⁾	400 ⁶⁾	636 ⁷⁾	320
2×R8i		2145 ²⁾	600 ⁶⁾	636 ⁷⁾	510
3×R8i		2145 ²⁾	800 ⁶⁾	636 ⁷⁾	660
4×R8i		2145 ²⁾	1200 ⁶⁾	636 ⁷⁾	1020
5×R8i		2145 ²⁾	1400 ⁶⁾	636 ⁷⁾	1170
6×R8i		2145 ²⁾	1600 ⁶⁾	636 ⁷⁾	1320
7×R8i		2145 ²⁾	2000 ⁶⁾	636 ⁷⁾	1680
8×R8i		2145 ²⁾	2200 ⁶⁾	636 ⁷⁾	1830
9×R8i		2145 ²⁾	2400 ⁶⁾	636 ⁷⁾	1980
10×R8i		2145 ²⁾	2800 ⁶⁾	636 ⁷⁾	2340
ACS880-1607 DC/DC converter⁹⁾					
R8i		2145 ⁸⁾	800	636	650
R8i		2145 ⁸⁾	800	636	680 ¹⁰⁾
2×R8i		2145 ⁸⁾	1600	636	1300
2×R8i		2145 ⁸⁾	1600	636	1360 ¹⁰⁾



Dimensions

ACS880 liquid-cooled multidrives

Frame size	Height (mm)	Width (mm)	Depth (mm)	Weight (kg)
ACS880-207LC IGBT supply unit (ISU).				
Dimensions include ACU, ICU, ISU and filter.				
R7i+BLCL-13LC-7	2002	1300	644	900
R8i+BLCL-15LC-7	2002	1900	644	900
2×R8i+BLCL-24LC-7	2002	2100	644	1030
2×R8i+BLCL-25LC-7	2002	2200	644	1180
3×R8i+2×BLCL-24LC-7	2002	2700	644	1800
4×R8i+2×BLCL-25LC-7	2002	3200	644	2360
5×R8i+3×BLCL-24LC-7	2002	3600	644	2830
6×R8i+4×BLCL-24LC-7	2002	4800	644	3600
8×R8i+4×BLCL-25LC-7	2002	5800	644	4720

ACS880-1007LC, liquid-cooling unit				
Unit type	Height (mm)	Width (mm)	Depth (mm)	Weight (kg)
ACS880-1007LC-0070	2002	330 (330) ²⁾	644	200
ACS880-1007LC-0195+C140	2002	630 (660) ²⁾	644	310
ACS880-1007LC-0195+C141	2002	630 (660) ²⁾	644	366
ACS880-1007LC-0195+C213	2002	630 (660) ²⁾	644	373

²⁾ For stand-alone liquid cooling unit.

Frame size	Height (mm)	Width (mm)	Depth (mm)	Weight (kg)
ACS880-107LC inverter unit (INU)				
R7i	2002	300	644	240
2×R7i ¹⁾	2002	400	644	310
R8i	2002	300	644	300
2×R8i	2002	500	644	430
3×R8i	2002	700	644	600
4×R8i	2002	1000	644	860
5×R8i	2002	1200	644	1030
6×R8i	2002	1400	644	1200
7×R8i	2002	1700	644	1460
8×R8i	2002	1900	644	1720
ACS880-1607LC DC/DC converter				
R7i	2002	300	644	240
R8i	2002	800	644	680/710 ²⁾
2×R8i	2002	1600	644	1425

¹⁾ Two individual inverters in one cabinet.

²⁾ 680 kg for 0400A-7 and 0500A-7



Standard interface and extensions for plug-in connectivity

—
01
Control unit ZCU
—
02
Example of a typical multidrives input/output connection diagram. Variations may be possible. For further information, please see the ACS880 user manual.

ACS880 multidrives offer a wide range of standard interfaces including extensive selection of I/O connections, Safe Torque Off (STO) and a galvanically isolated RS485 link that can be configured as either Modbus RTU or high speed drive-to-drive link.

In addition, the drive control unit (ZCU/BCU) has three option slots that can be used for extensions, including communication protocol adapters, input/output extension modules, feedback modules, and a safety functions module. For I/O extensions, see page 49.

Control unit ZCU for inverters (R1i to R7i) and diode supply unit (D6D to D8D) comes with three option slots for extension option modules.

Control unit BCU is used for inverters (nxR8i), IGBT supply unit, regenerative rectifier unit, DC/DC converter, brake units and diode supply unit (frame nxDXT). BCU comes with integrated branching unit, and three option slots with an additional slot for DDCS communication option.

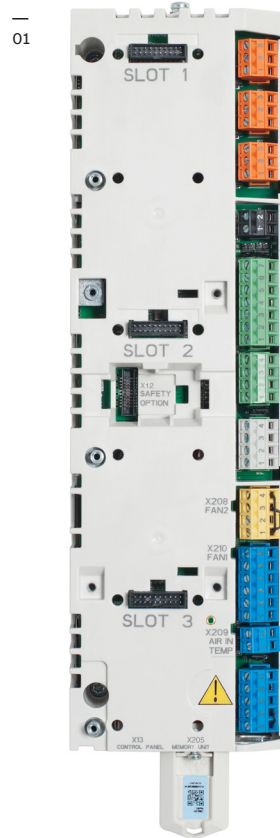

Control connections	Description
2 analog inputs (XA1)	Current input: -20 to 20 mA, R_{in} : 100 ohm Voltage input: -10 to 10 V, R_{in} > 200 kohm Resolution: 11 bit + sign bit
2 analog outputs (XAO)	0 to 20 mA, R_{load} < 500 ohm Frequency range: 0 to 300 Hz Resolution: 11 bit + sign bit
6 digital inputs (XDI)	Input type: NPN/PNP (DI1 to DI5), NPN (DI6) DI6 (XDI:6) can alternatively be used as an input for a PTC thermistor.
Digital input interlock (DIIL)	Input type: NPN/PNP
2 digital inputs/outputs (XDIO)	As input: 24 V logic levels: "0" < 5 V, "1" > 15 V R_{in} : 2.0 kohm Filtering: 0.25 ms As output: Total output current from 24 V DC is limited to 200 mA Can be set as pulse train input and output
3 relay outputs (XRO1, XRO2, XRO3)	250 V AC/30 V DC, 2 A
Safe Torque Off (XSTO)	For the drive to start, both connections must be closed, only to be used in inverter units
Drive-to-drive link (XD2D)	Physical layer: EIA-485
Built-in Modbus	EIA-485
Assistant control panel/PC tool connection	Connector: RJ-45

—
02

Relay outputs		XRO1, XRO2, XRO3	
Ready	NO	13	
250 V AC/30 V DC	COM	12	
2 A	NC	11	
Running	NO	23	
250 V AC/30 V DC	COM	22	
2 A	NC	21	
Faulted (-1)	NO	33	
250 V AC/30 V DC	COM	32	
2 A	NC	31	
External power input		XPOW	
24 V DC, 2 A	GND	2	
	+24VI	1	
Reference voltage and analog inputs		J1, J2, XAI	
AI1/AI2 current/voltage selection	AI1:U	AI2:U	
	AI1:I	AI2:I	
By default not in use. 0(4) to 20 mA, R _{in} = 100 ohm	AI2-	7	
	AI2+	6	
Speed reference 0(2) to 10 V, R _{in} > 200 kohm	AI1-	5	
	AI1+	4	
Ground	AGND	3	
-10 V DC, R _L 1 to 10 kohm	-VREF	2	
10 V DC, R _L 1 to 10 kohm	+VREF	1	
Analog outputs		XAO	
Motor current 0 to 20 mA, R _L < 500 ohm	AGND	4	
	AO2	3	
Motor speed rpm 0 to 20 mA, R _L < 500 ohm	AGND	2	
	AO1	1	
Drive-to-drive link		J3, XD2D	
Drive-to-drive link termination	ON <input type="checkbox"/> OFF <input type="checkbox"/>	Shield	4
Drive-to-drive link or built-in Modbus	BGND	3	
	A	2	
	B	1	
Safe Torque Off		XSTO	
Safe Torque Off. Both circuits must be closed for the drive to start.	IN2	4	
	IN1	3	
	SGND	2	
	OUT	1	
Digital inputs		XDI	
By default not in use	DI6	6	
Constant speed 1 select (1=on)	DI5	5	
Acceleration and deceleration select	DI4	4	
Reset	DI3	3	
Forward (0)/Reverse (1)	DI2	2	
Stop (0)/Start (1)	DI1	1	
Digital input/outputs		XDIO	
Output: Running	DIO2	2	
Output: Ready	DIO1	1	
Ground selection		XD24	
Digital input/output ground	DIOGND	5	
+24 V DC 200 mA	+24VD	4	
Digital input ground	DICOM	3	
+24 V DC 200 mA	+24VD	2	
Digital interlock	DIIL	1	
Safety functions module connection		X12	
Control panel/PC connection		X13	
Memory unit connection		X205	

Drive Assistant Control panels



- 01 Bluetooth assistant control panel, ACS-AP-W
- 02 Industrial assistant control panel without Bluetooth, ACS-AP-I
- 03 Drive Connectivity Panel
- 04 Control panel mounting platform DPMP-01
- 05 Control panel mounting platform DPMP-02
- 06 Control panel mounting platform, DPMP-04

Standard Bluetooth assistant control panel, ACS-AP-W and Industrial assistant control panel, ACS-AP-I

Assistant control panel with clear multilingual graphical display can be used for parameter setting and back-up, drive monitoring and operation, fault tracing and as a USB link for a PC tool. There are two different assistant control panels – with (ACS-AP-W) or without (ACS-AP-I) Bluetooth. The panels can be mounted either on the drive or on the door of the enclosure and they are compatible with any ABB all-compatible drive.

Control panel helps you to set up the essential settings quickly and get the drive into action. Also diagnostics is easy due to event history, clear text messages and real-time stamps.

Bluetooth control panel

The control panel with built-in Bluetooth enables easy and secure wireless connection with the Drivetune mobile app. With the entry version of Drive Composer software tool, you can startup, commission, maintain, and get remote support of ACS880 drives.

Drive Connectivity Panel

Control panel variant with built-in Bluetooth and mobile radio. It offers easy remote condition

monitoring, plug, and play installation with secure and reliable wireless connection to the ABB Ability™ Digital Powertrain, the cloud-based condition monitoring portal for ABB Drives. Possible to connect with the Drivetune mobile app and Drive Composer Entry PC tool as well. Available with a renewable subscription to the ABB Ability™ Digital Powertrain.*)

Control panel mounting platform, DPMP-01, is for flush mountings and has IP54/UL Type 12 protection class (IP20, when control panel is not mounted). Supports daisy chaining of the control panel link.

Control panel mounting platform, DPMP-02, is for surface mounting and has IP65 / UL Type 12 protection class (IP20, when control panel not mounted).

Control panel mounting platform, DPMP-04, is a lockable door mounting platform for drive control panels in outdoor installations or harsh environments. It has a IP66 protection class, UV resistance and IK07 impact protection rating.

*) Please contact your local ABB office to check availability.

Control panel options

Bluetooth Assistant control panel ACS-AP-W is included as standard in the delivery. ACS-AP-W (+J400) can be replaced by +J options below.

Option code	Ordering code for loose item	Description	Type
+0J400	—	No control panel	—
—	3AXD0000025965	Bluetooth Assistant control panel. Included as standard.	ACS-AP-W
+J425	3AUA0000088311	Industrial assistant control panel without Bluetooth connection	ACS-AP-I
+J410	3AUA0000108878	Control panel mounting platform, flush mounted, IP54 / UL Type 12 (does not include control panel)	DPMP-01
+J413	3AXD5000009374	Control panel mounting platform, surface mounted, IP65 / UL Type 12 (does not include control panel)	DPMP-02
—	3AXD50000217717	Control panel mounting platform for outdoor and harsh environments, IP66, UV resistance, IK07 impact protection rating (does not include control panel)	DPMP-04



Local ACS880 1400.0 Rpm
Save money
Save energy
Save nerves
Save all
Exit
Select

Stop

Loc/Rem

Start



?

Communication and connectivity

Fast and reliable communication

The **F-series fieldbus adapter modules** are flexible, plug-in adapters that provide fast and simple universal connectivity to all major controllers. Universal connectivity means ABB low voltage drives connect to automation controllers and communication networks, allowing users to choose the best network to meet their needs.

- Reduces mechanical and electrical cost
- Decrease in downtime
- Increase in productivity
- Diminished start-up costs
- Lower maintenance and diagnostic costs
- Quick access to networked drives with PC-based start-up and maintenance software tools
- Reductions in wiring costs compared to traditional I/O connections

Industrial automation plant – different network possibilities and their secure deployment

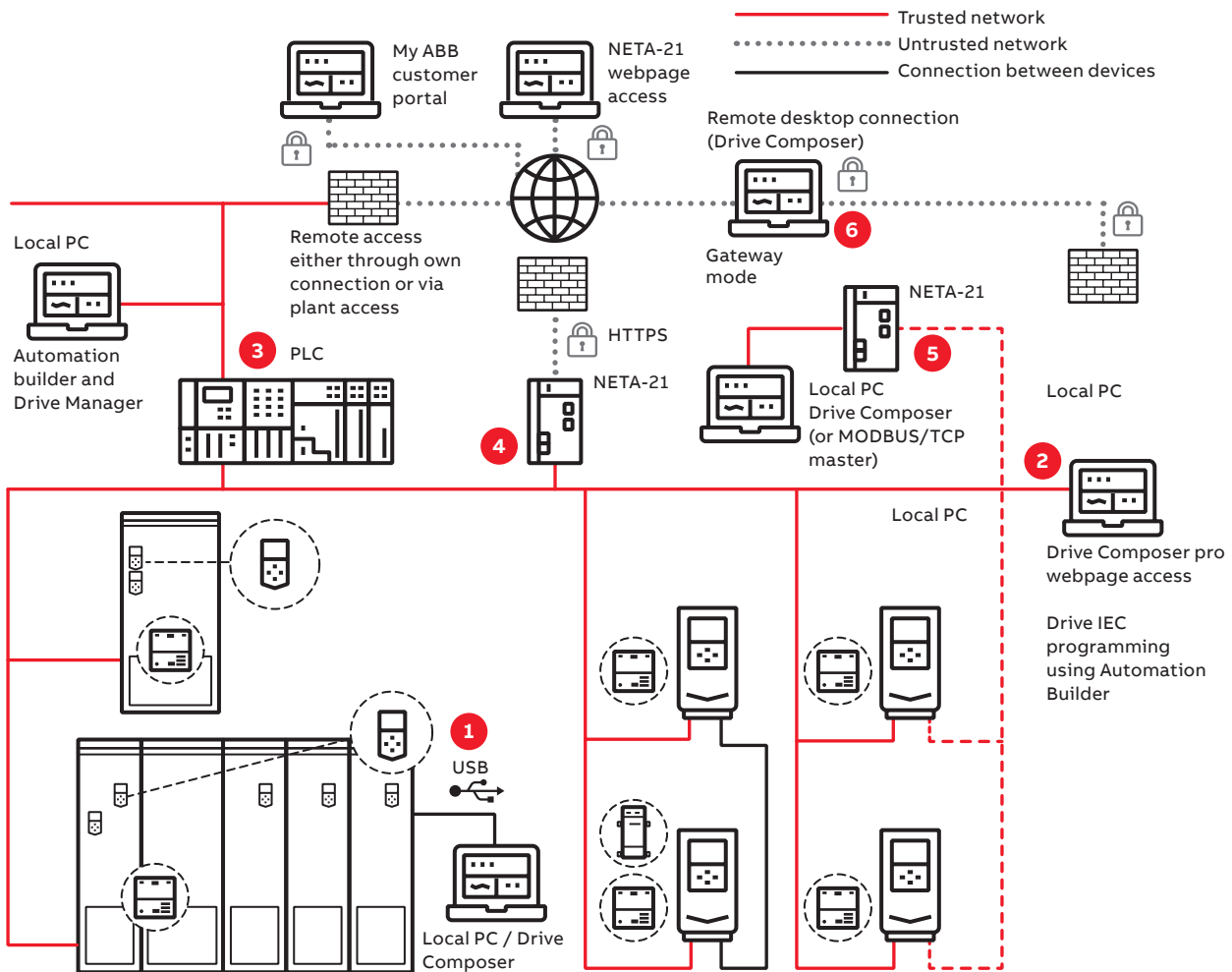

1. Local connections (point-to-point serial communication, e.g. USB) or
2. Shared (with control) upper-level physical fieldbus network (e.g., PROFINET) using Ethernet tool communication and/or
3. Communicating also through PLC system using Drive Manager device tool or
4. NETA-21 remote monitoring tool web interface or
5. NETA-21 acting as a gateway between or
6. Third-party remote desktop connection.

Connectivity to automation systems

—
01
ACS880 is compatible with many communication protocols
—
02
Input/output extension modules

Communication protocol adapters

ACS880 industrial drives are compatible with a wide range of communication protocols. The drive comes with a Modbus RTU fieldbus interface as standard.

The ACS880 supports two different communication connections simultaneously and offers the possibility for redundant communication. PROFIsafe (functional safety over PROFINET) is also supported.

Communication protocol adapters

Option code	Ordering code for loose item	Communication protocol	Adapter
+K451	68469341	DeviceNet™	FDNA-01
+K454	68469325	PROFIBUS DP, DPV0/DPV1	FPBA-01
+K457	68469376	CANopen®	FCAN-01
+K458	3AUA0000031336	Modbus RTU	FSCA-01
+K462	3AUA0000094512	ControlNet	FCNA-01
+K469	3AUA0000072069	EtherCAT®	FECA-01
+K470	3AXD5000019239	POWERLINK	FEPL-02
+K491	3AXD50000049964	Modbus/TCP	FMBT-21
+K492	3AXD50000192779	PROFINET IO	FPNO-21 ¹⁾
+K490	3AXD50000192786	EtherNet/IP	FEIP-21
+Q986	3AXD50000112821	PROFIsafe safety functions module	FSPS-21
+Q989	3AXD50001021061	CIP Safety functions module	FSCS-21

¹⁾ For the PROFIsafe to work the PROFINET adapter module (FPNO-21) and the safety functions module FSO-12 (+Q973) or FSO-21 (+Q972) are required. The FPNO-21 adapter module enables PROFINET system redundancy S2 allowing the drive to establish connection with two control PLCs in a redundant manner.

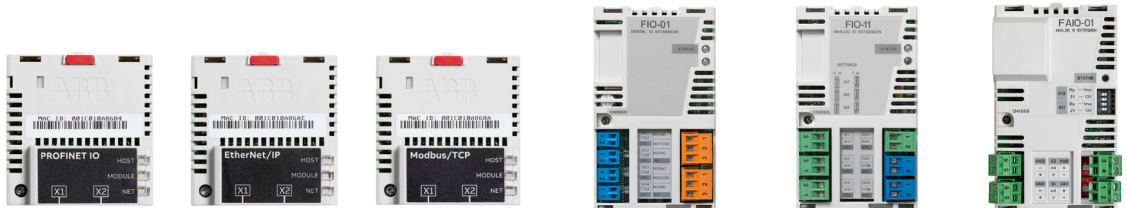

—
01

—
02

Input/output extension modules

Standard input and output can be extended by using optional analog and digital input/output extension modules. The modules are easily installed in the extension slots located on the drive.

If there are not enough I/O extension slots in the drive, the FEA-03 module can increase the number of slots. The FEA-03 has two option slots for digital I/O extensions and speed feedback interface modules. The connection to the control unit is via an optical fiber link, and the adapter can be mounted on a DIN rail (35 × 7.5 mm).

Analog and digital input/output extension modules

Option code	Ordering code for loose item	Description	I/O module
+L501	68805368	4×DI/O, 2×RO	FIO-01
+L500	68805384	3×AI (mA/V), 1×AO (mA), 2×DI/O	FIO-11
+L515	3AUA0000108669	2×F-type option extension slots	FEA-03
+L525	3AUA0000141436	2×AI (mA/V), 2×AO (mA)	FAIO-01
+L526	3AUA0000141438	3×DI (up to 250 V DC or 230 V AC), 2×RO	FDIO-01

PROFINET S2 system redundancy for ABB drives

System redundancy is a high-priority requirement in process industry and infrastructure installations where the system must be operational even during component breakdowns and malfunctioning. The interruption of a continuous production process could potentially lead to large financial losses or safety hazards. Thanks to the new PROFINET S2 system redundancy of ABB drives, the unwanted downtime can be minimized. This leads to better process control with improved productivity.

PROFINET system redundancy S2 is now available for ABB drives with the optional PROFINET interface module FPNO-21. It allows the drive to establish connection with two control PLCs in a redundant manner.

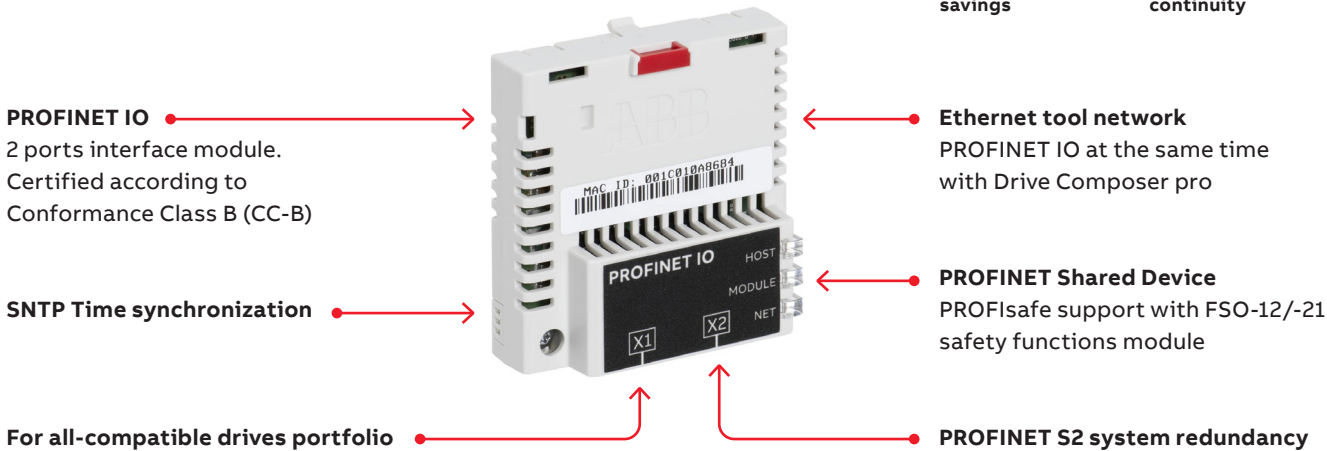
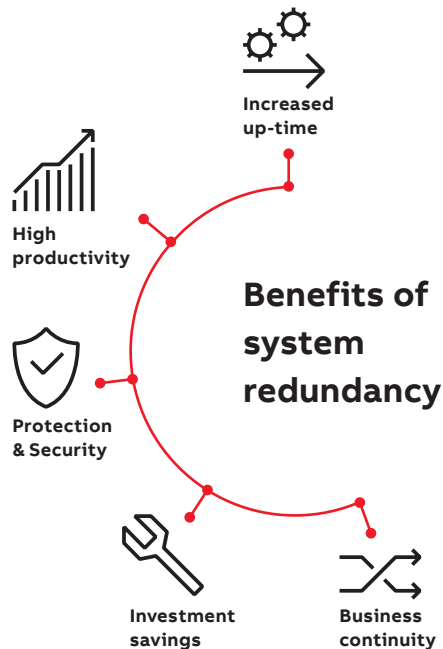



<https://new.abb.com/drives/connectivity/fieldbus-connectivity/profinet/fpno-21>

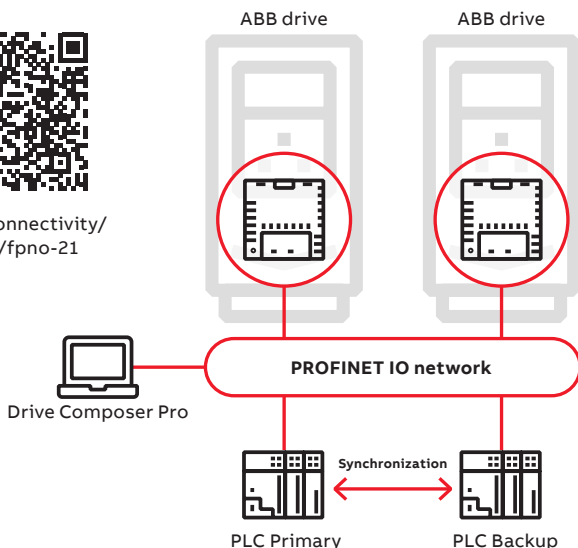

Feedback interface and DDCS communication options

- 01 FEN-01 TTL encoder interface module
- 02 FDCO-01 DDCS communication module

Speed feedback interfaces for precise process control

ACS880 drives can be connected to various feedback devices, such as HTL pulse encoders, TTL pulse encoders, absolute encoders and resolvers. The optional feedback module is installed in the option slot on the drive. It is possible to use two feedback modules at the same time, either of the same type or different types*).

*) Excluding FSE-31.

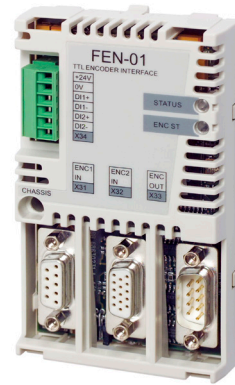

— 01

Feedback interface modules

Option code	Ordering code for loose item	Description	Feedback module
+L517	68805422	2 inputs (TTL pulse encoder), 1 output	FEN-01
+L518	68805830	2 inputs (SinCos absolute, TTL pulse encoder), 1 output	FEN-11
+L516	68805848	2 inputs (Resolver, TTL pulse encoder), 1 output	FEN-21
+L502	68978955	1 input (HTL pulse encoder), 1 output	FEN-31
+L521	3AXD5000023272	Pulse encoder interface for functional safety (for more details see section "Safety options")	FSE-31

DDCS communication option modules

The FDCO-0X optical DDCS communication options are add-on modules on the ACS880 industrial drives control unit. The modules include connectors for two fiber optic DDCS channels. The FDCO-0X modules make it possible to perform master-follower and AC800 M communication. Alternative way for drive to drive communication is to use the standard RS485 connection.



— 02

Optical communication modules

Option code	Ordering code for loose item	Description	Module
+L503	3AUA0000107392	Optical DDCS (10 Mbd/10 Mbd)	FDCO-01
+L508	3AUA0000107393	Optical DDCS (5 Mbd/10 Mbd)	FDCO-02

ABB Ability™ Digital Powertrain

Condition monitoring for drives

Accurate, real-time information about powertrain events. When you have the facts, you can make the right decisions.



ABB Ability™ Digital Powertrain

The ABB Ability™ Digital Powertrain enables you to remotely monitor the health and performance of entire powertrains including drives, motors and applications, such as pumps. The data collected from the connected equipment can be accessed and analyzed remotely, providing a better understanding of the health and energy efficiency of the entire process.

ABB Ability™ Condition Monitoring for drives

ABB Ability™ Condition Monitoring for drives is a key element of the Digital Powertrain. The services are designed to provide key information about drive events and changes in behavior to ensure your equipment is always available, reliable and well maintained.

The service can be tailored to fit your needs. Our standard package for condition monitoring for drives gives you industry leading monitoring capabilities – whether you want to view the drive status through ABB's Internet portal or integrate this data with your existing monitoring systems.

The standard package includes the following services:

- Condition Monitoring
- Alarm Management
- Asset Health
- Team Support
- Backup Management

The standard package can be supplemented with optional services:

- Offline Data Collection
- Expert Reports
- Remote Assistance
- Condition monitoring of your entire powertrain



Solid fact-based decision making

Get the facts, and the history, to help run your operations better and more safely.



Always stay one step ahead of problems

Recognize early signs of possible failures and assess the risks, before they turn into serious operational issues.



Find the root cause of process issues

Remotely access data from ABB drives built-in sensors to track the cause of problems. Get back to smooth operation quickly with data back-ups.



Remotely analyze and optimize drives

Get critical drive information anywhere anytime – even in difficult to access sites, or when a site visit is impossible.

Remote monitoring options

The NETA-21 remote monitoring tool gives easy access to the drive via the Internet or a local Ethernet network. NETA-21 comes with a built-in web server. Compatible with standard web browsers, it ensures easy access to a web-based user interface. Through the web interface, the user can configure drive parameters, and monitor drive log data, load levels, runtime, energy consumption, I/O data, and the bearing temperatures of the motor connected to the drive. One NETA-21 supports up to 10 ABB control units.

The remote data helps you to base your decisions on solid facts and run your operations better and safer.

Remote monitoring helps you to recognize early signs of potential failures and react before a problem occurs. You can also remotely access the data from ABB drives to analyze and find the root cause of a problem.

With remote access you can analyze and optimize drive information anywhere, even in sites that are difficult to access, or when site visit is not possible.

Remote monitoring option

Ordering code	Description	Type
3AUA0000094517	2 x panel bus interface max. 10 drives 2 x Ethernet interface SD memory card USB port for WLAN/3G	NETA-21



Customers can configure powertrains and customize the digital service plan

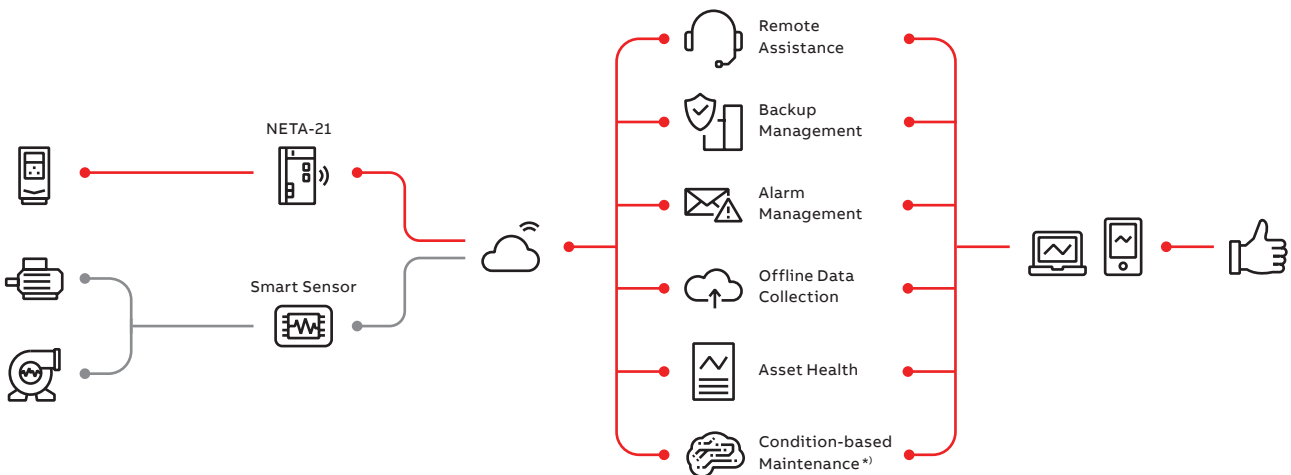

^{*)} Not available for all connectivity devices

Commissioning, programming and customization tools

Your engineering efficiency is boosted with our commissioning and programming tools, giving you the optimal solution to perform virtualization, planning, commissioning and maintenance.

Removable memory unit

The memory unit stores the drive software and settings, including motor data. This unit can be switched from one drive to another, allowing simple and rapid drive replacement without any special equipment, software loading, parameter settings, or other adjustments in the drive or automation system. It also eliminates the risk of software incompatibility. The new drive is ready to run as soon as the memory unit is plugged in.

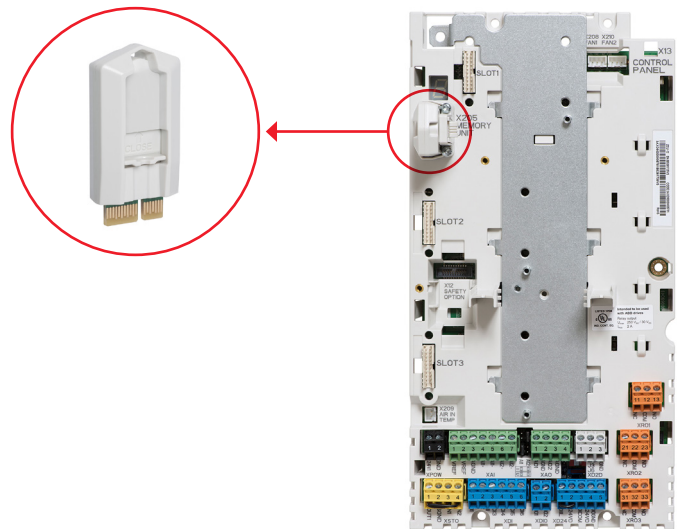

Drive Composer

The Drive Composer PC tool offers fast and harmonized setup, commissioning and monitoring for all-compatible drives. The free version of the tool provides startup and maintenance capabilities and gathers all drive information, such as parameter loggers, faults, backups and lists, into a support diagnostics file. Drive Composer pro provides additional features such as custom parameter windows, graphical control diagrams of the drive's configuration, and improved monitoring and diagnostics.

Drive Composer	Entry level (free)	Pro level
	Basic functionality	Entry-level features
	Parameter setting	Networked drives
	Point-to-point connection	Control diagrams
	Simple monitoring	Data logger(s)
	Supports adaptive programming	Graphical safety setup
	Adaptive programming in Demo mode	Adaptive (block) programming
	-	Multiple backup and restore
	-	Drive configuration by using virtual drive

Link/MRP codes	Description	Type designation
new.abb.com/drives/software-tools/drive-composer	Link to download free Drive Composer entry	-
9AKK105408A3415	Drive Composer entry PC tool (document)	-
3AUA0000108087	Drive Composer pro PC tool (single user license)	DCPT-01
3AUA0000145150	Drive Composer pro PC tool (10 users license)	DCPT-01
3AUA0000145151	Drive Composer pro PC tool (20 users license)	DCPT-01

Drive Application Builder

Drive Application Builder can be used for creating customized solutions. It is a drive application programming tool based on IEC61131 standard and enables full PLC programmability in ACS880.



Ordering code	Description	PC tool
3AXD50000342389	Standard version of the Drive Application Builder for IEC 61131-3 programming, DABS-STANDARD	Licenses for Drive Application Builder ¹⁾
3AXD50000343027	Software development productivity add-ons for Drive Application Builder, version control and static analysis extensions for improve software engineering productivity, single workstation, DABX-PRODUCTIVITY-ADD-ONS	
+N8010	License key for drive application programming based on IEC 61131-3 using Drive Application Builder	IEC programming

¹⁾ For IEC programming license key is needed for the ACS880 drive (+N8010)

Adaptive programming

Adaptive programming software, embedded inside the drive, is especially handy when there is a need to distribute some of the machine’s control logic to the drive. Adaptive programming brings energy savings when the drive is adjusted to control the application optimally. You can use our Drive Composer PC tool to set up the adaptive programming. Adaptive programming makes it possible to enhance the existing application control program to precisely fit users’ application needs. The program is also handy for ensuring that the drive’s electrical design is connected as it should be with working drive signals.

Adaptive programming

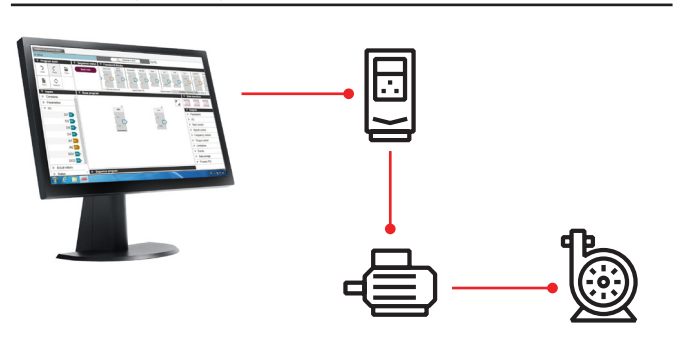

Safety options

—
01
FSO-12 safety
functions module

Integrated safety

Integrated safety reduces the need for external safety components, simplifying configuration and reducing installation space. The safety functionality is a built-in feature of the ACS880, with Safe Torque Off (STO) as standard. The STO function corresponds to an uncontrolled stop in accordance with stop category 0 of EN 60204-1. Additional safety functions can be commissioned with the optional and compact safety functions module. ACS880 drives offer functional safety with or without encoder. The drive's functional safety is designed in accordance with EN/IEC 61800-5-2 and complies with the requirements of the European Union Machinery Directive (2006/42/EC).

Safety functions are designed to the multidrives on project specific requirements.

The safety functions are certified by TÜV Nord and comply with the highest performance requirements (SIL 3 / PL e) in machinery safety.¹⁾

The safety functions module can also be ordered separately and installed afterwards to the drive.

PROFIsafe safety functions module, FSPS-21, with integrated PROFIsafe, and PROFINET IO connection supports STO and SS1-t safety functions. Since the functions are automatically configured, no additional safety settings are required in the drive.

Safety functions modules, FSO-12 and FSO-21, support a wide range of safety functions. Configuration of the functions is done with



—
01

the Drive Composer Pro PC tool, which provides an easy-to-use graphical user interface. Larger safety systems can be built using PROFIsafe over PROFINET connection between a safety PLC (such as AC500-S) and the ACS880 drive. The connection is achieved by adding a PROFINET adapter, FPNO-21, to the drive.

Supported safety functions:

- Encoderless: SS1-t, SS1-r, SLS, SBC, SMS, SSE, POUS, STO
- With encoder (requires FSO-21 + FSE-31): SDI, SSM, SS1-t, SS1-r, SLS, SBC, SMS, SSE, POUS, STO

Pulse encoder interface module, FSE-31, provides safe encoder data to the safety functions module, and can simultaneously be used as a feedback device for the drive. FSE-31 requires an FSO-21 safety functions module and supports HTL encoders.

Thermistor protection modules, FPTC-01 and FPTC-02

Safe temperature monitoring (STM) can be achieved by using FPTC thermistor protection modules¹⁾.

Safety function modules

Option code	Description	Safety module
+Q979 +Q973/ +Q972	Emergency Stop, configurable stop cat. 0 or 1; with STO, with safety functions module ²⁾	FSO-12/-21
+Q966 +Q973/+Q972	Safely-Limited Speed (SLS) with safety functions module (without encoder) ²⁾	FSO-12/-21
+Q965 + Q972 +L521	Safely-Limited Speed (SLS) with FSO-21 and with encoder FSE-31 ²⁾	FSO-21 and FSE-31
+Q950 +Q973/ +Q972	Prevention Of Unexpected Start-up (POUS) with safety functions module ²⁾	FSO-12/-21
+Q982 +Q972 +K492	PROFIsafe safety communication to be used together with FSO-21: forces to select a functional safety module and PROFINET adapter, FPNO-21	FSO-21 and FPNO-21
+L536	Thermistor protection module FPTC-01 ¹⁾	FPTC-01
+L537 +Q971	ATEX-certified thermistor protection module FPTC-02, Ex II (2) GD ¹⁾	FPTC-02

¹⁾ Thermistor modules comply with SIL 2 / PL c.

²⁾ Safety data and safety levels can be calculated for engineered solutions for multidrives cabinets as option. Safety level depends on configuration.

Safety function	Description	Supported functions		
		FSO-12 without encoder	FSO-21 + FSE-31 + HTL encoder	
Safe Stop 1 SS1-t SS1-r	Brings the machine to a stop using a monitored deceleration ramp. It is typically used in applications where the machinery motion needs to be brought to a stop (stop category 1) in a controlled way before switching over to the no-torque (STO) state	x (SS1-t) (SS1-r)	x (SS1-t) (SS1-r)	
Safe Stop Emergency SSE	Can be configured to, upon request, either activate STO instantly (category 0 stop), or first initiate motor deceleration and then, once the motor has stopped, activate the STO (category 1 stop).	x	x	
Safe Brake Control SBC	Provides a safe output for controlling the motor's external (mechanical) brakes, together with STO.	x	x	
Safely-Limited Speed SLS	Ensures that the specified speed limit of the motor is not exceeded. This allows machine interaction to be performed at slow speed without stopping the drive. The safety function module comes with four individual SLS settings for speed monitoring.	x	x	
Safe Maximum Speed SMS	Monitors that the speed of the motor does not exceed the configured maximum speed limit.	x	x	
Prevention Of Unexpected Start-up POUS	Ensures that the machine remains stopped when people are in the danger area.	x	x	
Safe Direction SDI	Ensures that rotation is allowed only in the selected direction. (Use only FSO-21 when HTL encoder is not needed. If HTL encoder is needed, both FSO-21 and FSE-31 must be used.)		x	
Safe Speed Monitor SSM	Provides a safe output signal to indicate whether the motor speed is between user-defined limits (available only with FSO-21).		x	
Safe Torque Off STO	Brings the drive safely to a no-torque state, i.e. switches off the drive output to the motor, motor speed then coasts to a stop. ACS880 has Safe Torque Off as standard.	x	x	

EMC – electromagnetic compatibility

Each ACS880 model can be equipped with a built-in filter to reduce high-frequency emissions.

What is EMC?

EMC stands for electromagnetic compatibility. It is the ability of electrical/electronic equipment to operate without problems in an electromagnetic environment.

Likewise, the equipment must not disturb or interfere with any other product or system in its locality. This is a legal requirement for all equipment taken into service within the European Economic Area (EEA).

Installation environments

A power drive system (PDS) can be connected to either industrial or public power distribution networks. The environment class depends on the way the PDS is connected to power supply.

The **1st environment** includes domestic premises. It also includes establishments directly connected without an intermediate transformer to a low voltage power supply network that supplies buildings used for domestic purposes.

The **2nd environment** includes all establishments directly connected to public low voltage power supply networks.

Immunity and emission compatibility

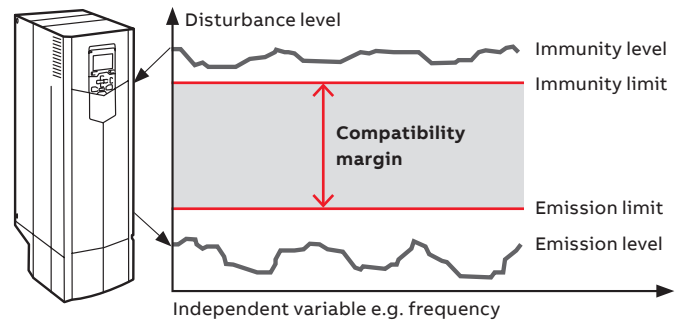

Installation environments

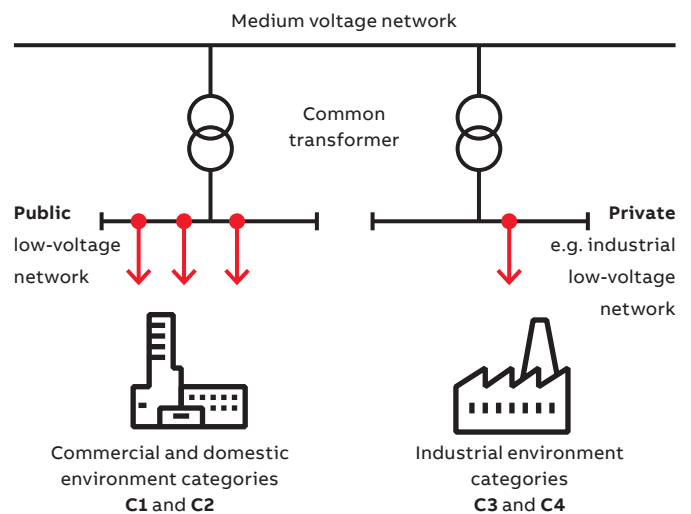

The product standard EN 61800-3 divides PDSs into four categories according to the intended use

C1 – 1st environment

- Household appliances
- Usually plug connectable to any wall outlet
- Anyone can connect these to the network
- Examples: washing machines, TV sets, computers, microwave ovens, etc.

C2 – 1st environment

- Fixed household and public appliances
- Need to be installed or operated by a professional
- Examples: elevators, rooftop fans, residential booster pumps, gates and barriers, supermarket freezers, etc.

C3 – 2nd environment

- Professional equipment
- Needs to be installed or operated by a professional
- In some rare cases, may also be pluggable
- Examples: any equipment for industrial usage only, such as conveyors, mixers, etc.

C4 – 2nd environment

- Professional equipment
- Needs to be fixed installation and operated by a professional
- Examples: paper machines, rolling mills, etc.

EMC standards				
EMC according to EN 61800-3:2004 + A1:2012 product standard	EN 61800-3 product standard	EN 55011, product family standard for industrial, scientific and medical (ISM) equipment	EN 61000-6-4, generic emission standard for industrial environments	EN 61000-6-3, generic emission standard for residential, commercial and light-industrial environment
1 st environment, unrestricted distribution	Category C1	Group 1. Class B	Not applicable	Applicable
1 st environment, restricted distribution	Category C2	Group 1. Class A	Applicable	Not applicable
2 nd environment, unrestricted distribution	Category C3	Group 2. Class A	Not applicable	Not applicable
2 nd environment, restricted distribution	Category C4	Not applicable	Not applicable	Not applicable

Selecting an EMC filter

Drive type	Voltage (V)	Frame sizes	1st environment, restricted distribution, C2, grounded network (TN) up to 1000 A Option code	2nd environment, C3, grounded network (TN) and ungrounded network (IT) Option code
ACS880-307	380 to 500	D6D to D8D	-	+E210 *)
	380 to 500	1xD8T	+E202	+E210 *)
	380 to 500	DxT up to 980 A	+E202	+E210 *)
ACS880-207	380 to 500	R8i	+E202	+E210 *)
	380 to 690	n×R8i	-	+E210 *)
ACS880-907	380 to 690	n×R8i	-	+E210 *)
ACS880-207LC	690	n×R8i	-	+E210 *)
ACS880-307LC	690	n×D8T	-	+E210 *)

*) Radiated emission and immunity

For potentially explosive atmosphere

ATEX certified

What is a potentially explosive atmosphere and where can it be?

Explosive atmospheres occur when flammable gases, mist, vapors or dust are mixed with air, which creates a risk of explosion. A potentially explosive area is defined as a location where there is a risk of flammable mixes. These atmospheres can be found throughout industries, from **chemical, pharmaceutical and food**, to **power and wood processing**. The electrical equipment that is installed in such locations must be designed and tested to endure these conditions and guarantee a safe function.



ATEX
 ATmosphères
 EXplosibles

What does ATEX mean?

The term ATEX comes from the French words "ATmosphères EXplosibles", and it is a combination of two EU directives: the Worker Protection Directive 1999/92/EC and the Product Directive 2014/34/ EU.

The ATEX Directives are designed to protect employees, the public and the environment from accidents owing to explosive atmospheres.

ATEX provides similar guidelines to the IECEx System, with a few exceptions, and with certification of protective devices (e.g. drive-integrated safety functions).



How to ensure safe operation?

With ABB's ATEX-certified offering and services, safe operation can be ensured.

Motors are directly connected to the machines in the potentially explosive atmosphere, and certain issues need to be considered when selecting a motor together with a drive. Drives themselves are not to be used in the potentially explosive atmosphere. These atmospheres have a defined zone classification, and the zone defines the minimum requirements (category) the motors must comply with. The category defines the permitted motor protection types.

Potentially explosive atmosphere zones

Within industries, all potentially explosive atmospheres are required to have an area classification called Zones. Globally, a Zone system is used to classify potentially explosive areas. The Worker Protection Directive 1999/92/EC and the EU standards IEC 60079-10-x, EN 60079-10-x define these zones. In all cases, the owner of the site where the potentially explosive atmosphere exists has the responsibility to define the zones according to the requirements.

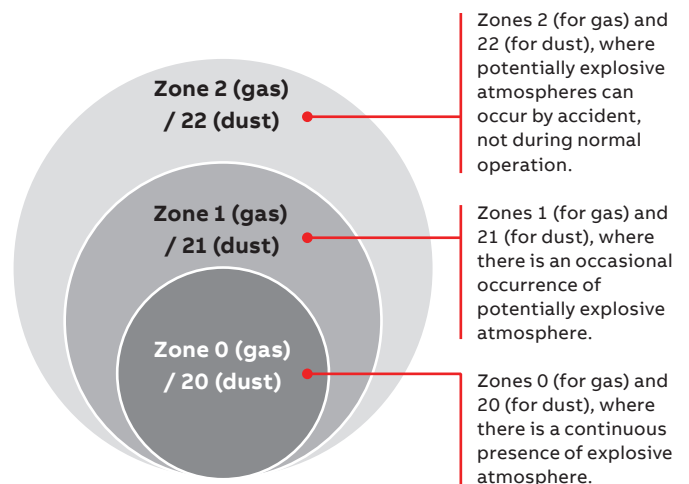

Tested packages



Motor and drive combinations are **tested and certified in ABB's test center**. By using an ABB motor together with an ABB drive as a package, you can enjoy the benefits of efficient, high-performance motors with optimal speed and control accuracy – without compromising on safety.

With the ABB ATEX certified motor and drive package the ATEX certified temperature protection modules are not obligatory, the tested combinations fulfill the IEC/ATEX standards and ensure safe performance.

- No additional testing and certification are needed
- No ATEX thermistor protection modules are needed
- Safe and cost effective solution for industries in potentially explosive atmospheres

Safe temperature monitoring



For non-tested and certified motors and drives (e.g. for use with other manufacturer's motors), ATEX certified temperature protection is an integrated option.

The ACS880's ATEX-certified thermistor protection module, Ex II (2) GD, FPTC-02, can be integrated into the drive if the motor is operating in a potentially explosive environment. **The purpose of the safety function is to disconnect the motor from the power supply before the motor overheats and causes a risk of explosion in an ATEX environment.**

Correct dimensioning

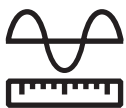

Correct dimensioning is important. **Correctly sized motors and drives reduce motor frame heating.** They also help to reduce energy use.

Insulation and drive filters



ABB's offering for correct insulation and filters **protects the motor** from voltage phenomena, bearing currents and motor overheating. The insulation and filters must be selected according to voltage and frame size.

Easy drive upgrades



With the drive upgrades below, the ATEX certification stays valid from the old to the new generation models. This means that there is no need for new ATEX certification during the upgrade. This saves you time and money.

ATEX certification approved – old generation model	Comparable converter upgrade	ATEX certification stays valid – new generation model
ACS600, ACS800, ACS850	→	ACS880

Global service and support network



ABB's global network of certified service providers are trained and experienced to help you with motors and drives for applications in explosive atmospheres.

The support network ensures that your ABB Declaration of Conformity is retained.

ABB's ATEX-certified thermistor protection module, Ex II (2) GD, FPTC-02

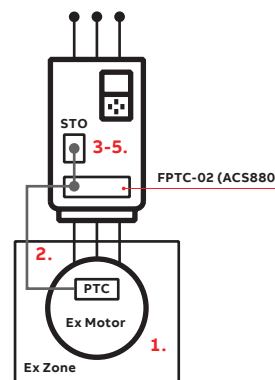

With option +L537 +Q971:

1. Motor temperature rises above the PTC sensor limit temperature.
2. The sensor resistance increases very sharply and indicates overheating to the ATEX-certified module, Ex II (2) GD.
3. The module switches the STO (Safe Torque Off) circuit off, which activates the STO function.
4. The STO function disables the control voltage in the power semiconductors of the drive output stage.
5. The drive is prevented from generating the required torque to rotate the motor.

► **The safe state is guaranteed**

Note:

The FPTC-02 module can be managed as a loose option and can also be retrofitted to the drive; in this case, to be compliant with regulations, the customer must ensure the following requirements:

- that the serial number of the drive/inverter module starts with 1, 4, 7, 8 or Y
- that the drive and option serial number is paired in a DIB (Drive Installed Base) portal
- that the included ATEX label for the SMT (Safe Motor Temperature) function is attached to the drive/inverter module to ensure the ATEX compliance of the safety circuit
- that the option module is installed in an option slot of the drive control unit and the applicable drive parameters are set
- that the PTC temperature sensors of the motor are connected to the PTC inputs of the option module.

* For further information please contact local ABB

ABB's ATEX-certified thermistor protection module

Option code	Ordering code	Description
+L537 +Q971	3AXD50000024924	ATEX-certified thermistor protection module FPTC-02, Ex II (2) GD

Sine filters

—
01
For step-up applications, e.g. where medium voltage motor needs to be driven

Together with a sine filter, ACS880 drives offer smooth motor operation. The sine filter suppresses the high-frequency components of the motor's output voltage, creating almost a sinusoidal voltage wave form for the motor. The filter offers an optimized LC design that takes into account the switching frequency, voltage drop and filtering characteristics.

The ACS880 inverter and sine filter solution can be used together with a variety of requirements for products and components:

- For motors without adequate insulation for the role
- Where the total motor cable length is long as a result of a number of parallel motors
- For step-up applications, e.g. where a medium voltage motor needs to be driven
- For submersible pumps with long motor cables, e.g. in the oil industry
- When the motor noise needs to be reduced
- When there are industry-specific requirements for peak voltage level and voltage rise time

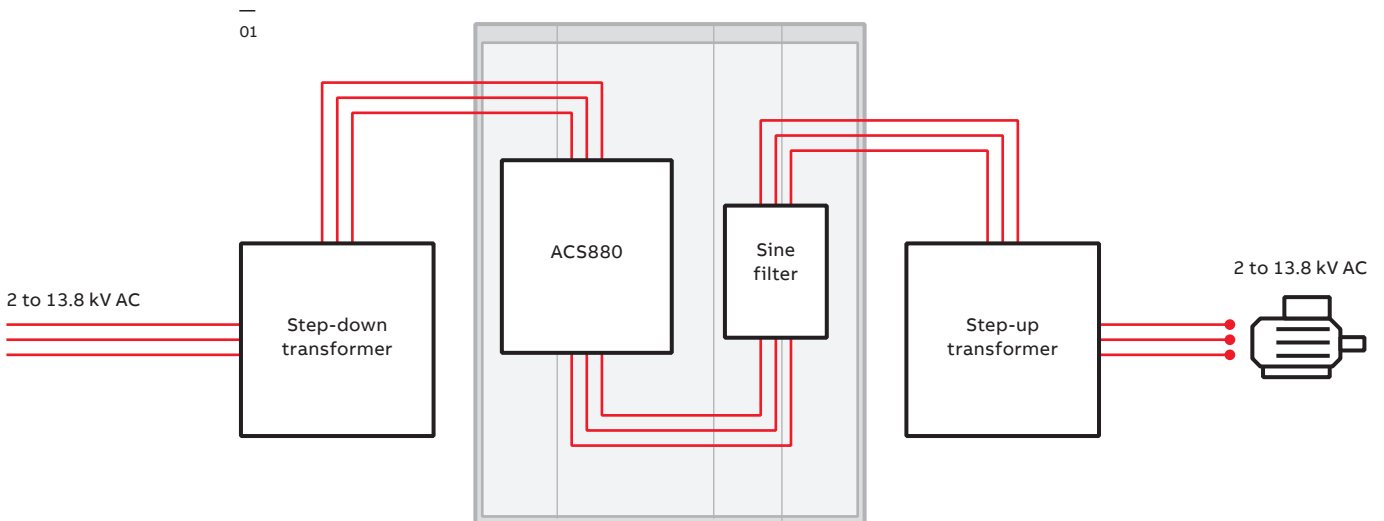

Sine filters for liquid-cooled multidrives

Sine filters are available as engineered options for liquid-cooled multidrives.

Sine filters for air-cooled multidrives

I_N (A)	P_N (kW)	Noise level (dB)	Inverter type	Filter type	Filter height (mm)	Filter width (mm)	Filter depth (mm)	Filter weight (kg)	Frame size
$U_N = 400\text{ V}$ (range 380 to 415 V). The power ratings are valid at nominal voltage 400 V.									
470	250	80	ACS880-107-0470A-3	NSIN-0900-6	2145	1000	636	550	R8i
640	355	80	ACS880-107-0640A-3	NSIN-0900-6	2145	1000	636	550	R8i
760	400	80	ACS880-107-0760A-3	NSIN-0900-6	2145	1000	636	550	R8i
900	500	81	ACS880-107-0900A-3	NSIN-1380-6	2145	1000	636	750	R8i
1250	630	82	ACS880-107-1250A-3	2×NSIN-0900-6	2145	1000	636	1100	2×R8i
1480	800	82	ACS880-107-1480A-3	2×NSIN-0900-6	2145	2000	636	1100	2×R8i
1760	1000	82	ACS880-107-1760A-3	2×NSIN-1380-6	2145	2000	636	1500	2×R8i
2210	1200	82	ACS880-107-2210A-3	2×NSIN-1380-6	2145	2000	636	1500	3×R8i
2610	1400	83	ACS880-107-2610A-3	3×NSIN-1380-6	2145	3000	636	2250	3×R8i
3450	1800	83	ACS880-107-3450A-3	3×NSIN-1380-6	2145	3000	636	2250	4×R8i
4290	2400	84	ACS880-107-4290A-3	4×NSIN-1380-6	2145	4000	636	3000	5×R8i
5130	2800	85	ACS880-107-5130A-3	5×NSIN-1380-6	2145	5000	636	3750	6×R8i
$U_N = 500\text{ V}$ (range 380 to 500 V). The power ratings are valid at nominal voltage 500 V.									
440	250	80	ACS880-107-0440A-5	NSIN-0485-6	2145	400	636	350	R8i
590	400	80	ACS880-107-0590A-5	NSIN-0900-6	2145	1000	636	550	R8i
740	500	80	ACS880-107-0740A-5	NSIN-0900-6	2145	1000	636	550	R8i
810	560	81	ACS880-107-0810A-5	NSIN-1380-6	2145	1000	636	750	R8i
1150	800	81	ACS880-107-1150A-5	NSIN-1380-6	2145	1000	636	750	2×R8i
1450	1000	82	ACS880-107-1450A-5	2×NSIN-0900-6	2145	2000	636	1100	2×R8i
1580	1100	82	ACS880-107-1580A-5	2×NSIN-1380-6	2145	2000	636	1500	2×R8i
2150	1500	82	ACS880-107-2150A-5	2×NSIN-1380-6	2145	2000	636	1500	3×R8i
2350	1600	83	ACS880-107-2350A-5	3×NSIN-1380-6	2145	3000	636	2250	3×R8i
3110	2000	83	ACS880-107-3110A-5	3×NSIN-1380-6	2145	3000	636	2250	4×R8i
3860	2400	84	ACS880-107-3860A-5	4×NSIN-1380-6	2145	4000	636	3000	5×R8i
4610	3200	85	ACS880-107-4610A-5	5×NSIN-1380-6	2145	5000	636	3750	6×R8i
$U_N = 690\text{ V}$ (range 525 to 690 V). The power ratings are valid at nominal voltage 690 V.									
340	315	80	ACS880-107-0340A-7	NSIN-0485-6	2145	400	636	350	R8i
410	400	80	ACS880-107-0410A-7	NSIN-0485-6	2145	400	636	350	R8i
530	500	80	ACS880-107-0530A-7	NSIN-0900-6	2145	1000	636	550	R8i
600	560	80	ACS880-107-0600A-7	NSIN-0900-6	2145	1000	636	550	R8i
800	800	80	ACS880-107-0800A-7	NSIN-0900-6	2145	1000	636	550	2×R8i
1030	1000	81	ACS880-107-1030A-7	NSIN-1380-6	2145	1000	636	750	2×R8i
1170	1100	81	ACS880-107-1170A-7	NSIN-1380-6	2145	1000	636	750	2×R8i
1540	1400	82	ACS880-107-1540A-7	2×NSIN-1380-6	2145	2000	636	1500	3×R8i
1740	1600	82	ACS880-107-1740A-7	2×NSIN-1380-6	2145	2000	636	1500	3×R8i
2300	2000	82	ACS880-107-2300A-7	2×NSIN-1380-6	2145	2000	636	1500	4×R8i
2860	2800	83	ACS880-107-2860A-7	3×NSIN-1380-6	2145	3000	636	2250	5×R8i
3420	3200	83	ACS880-107-3420A-7	3×NSIN-1380-6	2145	3000	636	2250	6×R8i
3990	3600	84	ACS880-107-3990A-7	4×NSIN-1380-6	2145	4000	636	3000	7×R8i
4560	4400	84	ACS880-107-4560A-7	4×NSIN-1380-6	2145	4000	636	3000	8×R8i
5130	4800	85	ACS880-107-5130A-7	5×NSIN-1380-6	2145	5000	636	3750	9×R8i
5700	5600	86	ACS880-107-5700A-7	6×NSIN-1380-6	2145	6000	636	4500	10×R8i

Nominal ratings

I_N	Rated current of the drive-filter combination available continuously without overload at 40 °C.
P_N	Typical motor power

Brake options

—
01
NBRA659 brake unit

Brake unit

The brake unit is a cabinet-built option. It handles the energy generated by a decelerating motor. The brake chopper connects the brake resistor to the intermediate DC circuit whenever the voltage in the circuit exceeds the limit defined by the control program. Energy consumption by the resistor losses lowers the voltage until the resistor can be disconnected.

Brake resistor for 1-phase brake units

The brake resistors are separately available for ACS880 multidrive cabinets as an option. Resistors other than the standard option resistors may be used, provided that the specified resistance value is not decreased and that the heat dissipation capacity of the resistor is sufficient for the drive application.

Dynamic braking unit

A brake chopper for application where high continuous braking power is needed. The power range is 500 to 6500 kW.



—
01

ACS880-607, 1-phase brake units

$U_N = 400\text{ V}$ (range 380 to 415 V)

Nominal ratings					Duty cycle (1 min/5 min)	Duty cycle (10 s/60 s)	Height ²⁾	Width ^{1) 3)}	Depth	Noise	Air flow	Brake unit type ACS880-607-	Brake chopper module type	Resistor type	
$P_{br,max}$ (kW)	R (ohm)	I_{max} (A)	I_{rms} (A)	$P_{cont.}$ (kW)	$P_{br.}$ (kW)	I_{rms} (A)	$P_{br.}$ (kW)	I_{rms} (A)	(mm)	(mm)	(mm)	(dB(A))	(m ³ /h)		
Brake unit without brake resistor															
353	1.20	545	149	96	303	468	353	545	2130	400	644	64	660	0320-3 NBRA659	—
706	0.60	1090	298	192	606	936	706	1090	2130	800	644	67	1320	0640-3 2×NBRA659	—
1058	0.40	1635	447	288	909	1404	1059	1635	2130	1200	644	68	1980	0960-3 3×NBRA659	—
1411	0.30	2180	596	384	1212	1872	1412	2180	2130	1600	644	69	2640	1280-3 4×NBRA659	—
1764	0.24	2725	745	480	1515	2340	1765	2725	2130	2000	644	70	3300	1600-3 5×NBRA659	—
2117	0.20	3270	894	576	1818	2808	2118	3270	2130	2400	644	71	3960	1920-3 6×NBRA659	—
Brake unit with brake resistor															
353	1.20	545	84	54	167	257	287	444	2130	1200	644	66	2500	0320-3+D151*)	NBRA659 2×SAFUR180F460
706	0.60	1090	168	108	333	514	575	888	2130	2400	644	69	5000	0640-3+D151*)	2×NBRA659 2×(2×SAFUR180F460)
1058	0.40	1635	252	162	500	771	862	1332	2130	3600	644	70	7500	0960-3+D151*)	3×NBRA659 3×(2×SAFUR180F460)
1411	0.30	2180	336	216	667	1028	1150	1776	2130	4800 ¹⁾	644	71	10000	1280-3+D151*)	4×NBRA659 4×(2×SAFUR180F460)
1764	0.24	2725	420	270	833	1285	1437	2220	2130	6000 ¹⁾	644	72	12500	1600-3+D151*)	5×NBRA659 5×(2×SAFUR180F460)
2117	0.20	3270	504	324	1000	1542	1724	2664	2130	7200 ¹⁾	644	73	15000	1920-3+D151*)	6×NBRA659 6×(2×SAFUR180F460)

$U_N = 500\text{ V (range 380 to 500 V)}$																
Nominal ratings				Duty cycle (1 min/5 min)	Duty cycle (10 s/60 s)	Height ²⁾	Width ^{1) 3)}	Depth	Noise	Air flow	Brake unit type ACS880-607-	Brake chopper module type	Resistor type			
$P_{br,max}$ (kW)	R (ohm)	I_{max} (A)	I_{rms} (A)	$P_{cont.}$ (kW)	$P_{br.}$ (kW)	I_{rms} (A)	$P_{br.}$ (kW)	I_{rms} (A)	(mm)	(mm)	(mm)	(dB(A))	(m ³ /h)			
Brake unit without brake resistor																
403	1.43	571	136	109	317	391	403	498	2130	400	644	64	660	0400-5	NBRA659	–
806	0.72	1142	272	218	634	782	806	996	2130	800	644	67	1320	0800-5	2×NBRA659	–
1208	0.48	1713	408	327	951	1173	1209	1494	2130	1200	644	68	1980	1200-5	3×NBRA659	–
1611	0.36	2284	544	436	1268	1564	1612	1992	2130	1600	644	69	2640	1600-5	4×NBRA659	–
2014	0.29	2855	680	545	1585	1955	2015	2490	2130	2000	644	70	3300	2000-5	5×NBRA659	–
2417	0.24	3426	816	654	1902	2346	2418	2988	2130	2400	644	71	3960	2400-5	6×NBRA659	–
Brake unit with brake resistor																
403	1.35	605	67	54	167	206	287	355	2130	1200	644	66	2500	0400-5+D151 ^{*)}	NBRA659	2×SAFUR200F500
806	0.68	1210	134	108	333	412	575	710	2130	2400	644	69	5000	0800-5+D151 ^{*)}	2×NBRA659	2×(2×SAFUR200F500)
1208	0.45	1815	201	162	500	618	862	1065	2130	3600	644	70	7500	1200-5+D151 ^{*)}	3×NBRA659	3×(2×SAFUR200F500)
1611	0.34	2420	268	216	667	824	1150	1420	2130	4800 ¹⁾	644	71	10000	1600-5+D151 ^{*)}	4×NBRA659	4×(2×SAFUR200F500)
2014	0.27	3025	335	270	833	1030	1437	1775	2130	6000 ¹⁾	644	72	12500	2000-5+D151 ^{*)}	5×NBRA659	5×(2×SAFUR200F500)
2417	0.23	3630	402	324	1000	1236	1724	2130	2130	7200 ¹⁾	644	73	15000	2400-5+D151 ^{*)}	6×NBRA659	6×(2×SAFUR200F500)

$U_N = 690\text{ V (range 525 to 690 V)}$																
Nominal ratings				Duty cycle (1 min/5 min)	Duty cycle (10 s/60 s)	Height ²⁾	Width ^{1) 3)}	Depth	Noise	Air flow	Brake unit type ACS880-607-	Brake chopper module type	Resistor type			
$P_{br,max}$ (kW)	R (ohm)	I_{max} (A)	I_{rms} (A)	$P_{cont.}$ (kW)	$P_{br.}$ (kW)	I_{rms} (A)	$P_{br.}$ (kW)	I_{rms} (A)	(mm)	(mm)	(mm)	(dB(A))	(m ³ /h)			
Brake unit without brake resistor																
404	2.72	414	107	119	298	267	404	361	2130	400	644	64	660	0400-7	NBRA669	–
807	1.36	828	214	238	596	534	808	722	2130	800	644	67	660	0800-7	2×NBRA669	–
1211	0.91	1242	321	357	894	801	1212	1083	2130	1200	644	68	1320	1200-7	3×NBRA669	–
1615	0.68	1656	428	476	1192	1068	1616	1444	2130	1600	644	69	1980	1600-7	4×NBRA669	–
2019	0.54	2070	535	595	1490	1335	2020	1805	2130	2000	644	70	2640	2000-7	5×NBRA669	–
2422	0.45	2484	642	714	1788	1602	2424	2166	2130	2400	644	71	3300	2400-7	6×NBRA669	–
Brake unit with brake resistor																
404	1.35	835	97	54	167	149	287	257	2130	1200	644	66	2500	0400-7+D151 ^{*)}	NBRA669	2×SAFUR200F500
807	0.68	1670	194	108	333	298	575	514	2130	2400	644	69	5000	0800-7+D151 ^{*)}	2×NBRA669	2×(2×SAFUR200F500)
1211	0.45	2505	291	162	500	447	862	771	2130	3600	644	70	7500	1200-7+D151 ^{*)}	3×NBRA669	3×(2×SAFUR200F500)
1615	0.34	3340	388	216	667	596	1150	1028	2130	4800 ¹⁾	644	71	10000	1600-7+D151 ^{*)}	4×NBRA669	4×(2×SAFUR200F500)
2019	0.27	4175	485	270	833	745	1437	1285	2130	6000 ¹⁾	644	72	12500	2000-7+D151 ^{*)}	5×NBRA669	5×(2×SAFUR200F500)
2422	0.23	5010	582	324	1000	894	1724	1542	2130	7200 ¹⁾	644	73	15000	2400-7+D151 ^{*)}	6×NBRA669	6×(2×SAFUR200F500)

Ratings

E_r	Energy pulse that the resistor assembly will withstand with the 400 seconds duty cycle. This energy will heat the resistor element from 40 °C to the maximum allowable temperature.
$P_{br,max}$	Maximum braking power of the NBRA-6xx chopper and SAFUR resistor combination.
Note:	The braking energy transmitted to the resistor during any period shorter than 400 seconds may not exceed E_r . Thus, the standard resistor withstands continuous braking of $P_{br,max}$ typically 20 to 40 seconds ($t = E_r / P_{br,max}$) during the total cycle time of 400 s.
R	Recommended braking resistor resistance. Also nominal resistance of corresponding SAFUR resistor. Dedicated resistor for each brake chopper.
I_{max}	Maximum peak current per chopper during braking. Current is achieved with minimum resistor resistance.
I_{rms}	Corresponding rms current per chopper during load cycle.

Heat loss of brake chopper is 1% of braking power. Heat loss of section with brake resistors is the same as braking power.

¹⁾ Additional 200 mm junction section needed.

²⁾ 2130 mm + additional 10 mm is required for marine supports.

³⁾ Total width of the line-up is the sum of widths of the sections + 30 mm for the end plates.

^{*)} D151 = braking resistor, degree of protection IP22 and IP42 only

ACS880-607, 3-phase dynamic brake units

$U_N = 400\text{ V}$ (range 380 to 415 V)																	
Resistor values		Ratings R_{min}							Ratings R_{max}							Brake unit type ACS880-607-	Frame size
		No-overload use				Cycle load (1 min/5 min)			No-overload use				Cycle load (1 min/5 min)				
R_{min}	R_{max}	I_{dc} DC	I_{rms} DC	$P_{cont.max}$ (kW)	I_{max} DC	I_{dc} DC	I_{rms} DC	R_{min} DC	$P_{br.}$ R_{min} DC	I_{dc} DC	I_{rms} DC	$P_{cont.max}$ (kW)	I_{max} DC	I_{dc} DC	I_{rms} DC	R_{max} DC	$P_{br.}$ R_{max} DC
(ohm)	(ohm)	(A)	(A)	(kW)	(A)	(A)	(A)	(A)	(A)	(A)	(A)	(kW)	(A)	(A)	(A)	(A)	(A)
1.7	2.1	781	310	500	370	999	351	640	781	282	500	312	827	291	530	0500-3	R8i
1.2	1.4	1171	465	750	555	1499	527	960	1171	424	750	468	1241	436	800	0750-3	R8i
1.7	2.1	1562	621	1000	740	1998	702	1290	1562	565	1000	625	1655	581	1060	1000-3	2×R8i
1.2	1.4	2342	931	1510	1110	2997	1053	1930	2342	847	1510	937	2482	872	1600	1510-3	2×R8i
1.2	1.4	3514	1396	2260	1665	4496	1580	2890	3514	1271	2260	1405	3723	1308	2400	2260-3	3×R8i
1.2	1.4	4685	1862	3010	2220	5994	2106	3860	4685	1694	3010	1874	4964	1744	3190	3010-3	4×R8i
1.2	1.4	5856	2327	3770	2775	7493	2633	4820	5856	2118	3770	2342	6205	2180	3990	3770-3	5×R8i

$U_N = 500\text{ V}$ (range 380 to 500 V)																	
Resistor values		Ratings R_{min}							Ratings R_{max}							Brake unit type ACS880-607-	Frame size
		No-overload use				Cycle load (1 min/5 min)			No-overload use				Cycle load (1 min/5 min)				
R_{min}	R_{max}	I_{dc} DC	I_{rms} DC	$P_{cont.max}$ (kW)	I_{max} DC	I_{dc} DC	I_{rms} DC	R_{min} DC	$P_{br.}$ R_{min} DC	I_{dc} DC	I_{rms} DC	$P_{cont.max}$ (kW)	I_{max} DC	I_{dc} DC	I_{rms} DC	R_{max} DC	$P_{br.}$ R_{max} DC
(ohm)	(ohm)	(A)	(A)	(kW)	(A)	(A)	(A)	(A)	(A)	(A)	(A)	(kW)	(A)	(A)	(A)	(A)	(A)
2.2	2.6	781	310	630	370	999	351	800	781	284	630	312	835	293	670	0630-5	R8i
1.4	1.7	1171	465	940	555	1499	527	1210	1171	430	940	468	1277	449	1030	0940-5	R8i
2.2	2.6	1562	621	1260	740	1998	702	1610	1562	568	1260	625	1671	587	1340	1260-5	2×R8i
1.4	1.7	2342	931	1880	1110	2997	1053	2410	2342	860	1880	937	2555	898	2060	1880-5	2×R8i
1.4	1.7	3514	1396	2830	1665	4496	1580	3620	3514	1289	2830	1405	3832	1347	3080	2830-5	3×R8i
1.4	1.7	4685	1862	3770	2220	5994	2106	4820	4685	1719	3770	1874	5110	1795	4110	3770-5	4×R8i
1.4	1.7	5856	2327	4710	2775	7493	2633	6030	5856	2149	4710	2342	6387	2244	5140	4710-5	5×R8i

$U_N = 690\text{ V}$ (range 525 to 690 V)																	
Resistor values		Ratings R_{min}							Ratings R_{max}							Brake unit type ACS880-607-	Frame size
		No-overload use				Cycle load (1 min/5 min)			No-overload use				Cycle load (1 min/5 min)				
R_{min}	R_{max}	I_{dc} DC	I_{rms} DC	$P_{cont.max}$ (kW)	I_{max} DC	I_{dc} DC	I_{rms} DC	R_{min} DC	$P_{br.}$ R_{min} DC	I_{dc} DC	I_{rms} DC	$P_{cont.max}$ (kW)	I_{max} DC	I_{dc} DC	I_{rms} DC	R_{max} DC	$P_{br.}$ R_{max} DC
(ohm)	(ohm)	(A)	(A)	(kW)	(A)	(A)	(A)	(A)	(A)	(A)	(A)	(kW)	(A)	(A)	(A)	(A)	(A)
3.0	3.6	781	310	870	370	999	351	1110	781	283	870	312	833	293	920	0870-7	R8i
2.0	2.4	1171	465	1300	555	1499	527	1660	1171	425	1300	468	1249	439	1390	1300-7	R8i
3.0	3.6	1562	621	1730	740	1998	702	2220	1562	567	1730	625	1665	585	1850	1730-7	2×R8i
2.0	2.4	2342	931	2600	1110	2997	1053	3330	2342	850	2600	937	2498	878	2770	2600-7	2×R8i
2.0	2.4	3514	1396	3900	1665	4496	1580	4990	3514	1275	3900	1405	3746	1316	4160	3900-7	3×R8i
2.0	2.4	4685	1862	5200	2220	5994	2106	6650	4685	1700	5200	1874	4995	1755	5540	5200-7	4×R8i
2.0	2.4	5856	2327	6500	2775	7493	2633	8320	5856	2125	6500	2342	6244	2194	6930	6500-7	5×R8i

Dimensions

Frame size	Height ¹⁾ (mm)	Width bottom exit (mm)	Width top exit (mm)	Depth (mm)	Noise level ²⁾ (dB(A))	Air flow (m ³ /h)
R8i	2145	500	700	636	72	1300
2×R8i	2145	1000	1400	636	74	2600
3×R8i	2145	1500	2100	636	76	3900
4×R8i	2145	2000	2800	636	76	5200
5×R8i	2145	2500	3500	636	77	6500

¹⁾ IP21 and IP42. IP54 additional 170 mm to the height of each R8i cabinet.

²⁾ Average noise level with controlled cooling fan.

Note: 400 mm free space needed above cabinet.

Resistor	
R_{min}	Minimum allowed resistance value of the brake resistor for one phase of the brake module.
R_{max}	Resistance value of the brake resistor for one phase of the brake module corresponding to the maximum achieved continuous braking power.
Note:	Connect one resistor per brake module phase. For example, a brake unit of frame size 2xR8i including two brake modules → 2x3 resistors are needed.

Typical ratings for no-overload use	
I_{dc}	Total input DC current of brake unit.
I_{rms}	Total rms DC output phase current of brake unit.
I_{max}	Peak brake current (DC) per chopper module phase.
$P_{cont,max}$	Maximum continuous braking power per brake unit.

Cyclic load (1 min/5 min)	
I_{dc}	Total input DC current of brake unit during a period of 1 minute with braking power P_{br} .
I_{rms}	Total rms DC current per brake unit phase during a period of 1 minute with braking power P_{br} .
P_{br}	Short term braking power

ACS880-607LC liquid cooled 1-phase brake units

$U_N = 690\text{ V (range 525 to 690 V)}$																		
Nominal ratings					Duty cycle (1min/5min)	Duty cycle (10s/60s)	Losses ³⁾	Coolant flow rate ¹⁾	Air flow ²⁾	Height	Width ¹⁾	Depth	Brake chopper module type	Brake resistor type	Type ACS880-607LC-			
$P_{br,max}$ (kW)	R_{tot} (ohm)	I_{max} (A)	I_{rms} (A)	$P_{br,cont}$ (kW)	P_{br} (kW)	I_{rms} (A)	P_{br} (kW)	I_{rms} (A)	P_{loss} (kW)	(l/min)	(m ³ /h)	(mm)	(mm)	(mm)				
404	-	414	107	119	298	267	404	361	2.0	1.6	-	2002	400	644	NBRW-669C	-	0400-7	
807	-	828	214	238	596	534	808	722	4.0	3.2	-	2002	800	644	2xNBRW-669C	-	0800-7	
1211	-	1242	321	357	894	801	1212	1083	6.0	4.8	-	2002	1200	644	3xNBRW-669C	-	1200-7	
1615	-	1656	428	476	1192	1068	1616	1444	8.0	6.4	-	2002	1600	644	4xNBRW-669C	-	1600-7	
2019	-	2070	535	595	1490	1335	2020	1805	10.0	8.0	-	2002	2000	644	5xNBRW-669C	-	2000-7	
2422	-	2484	642	714	1788	1602	2424	2166	12.0	9.6	-	2002	2400	644	6xNBRW-669C	-	2400-7	

$U_N = 690\text{ V (range 525 to 690 V)}$																		
Nominal ratings					Duty cycle (1min/5min)	Duty cycle (10s/60s)	Coolant flow rate ¹⁾	Air flow ²⁾	Height	Width ¹⁾	Depth	Brake chopper module type	Brake resistor type	Type ACS880-607LC-				
$P_{br,max}$ (kW)	R_{tot} (ohm)	I_{max} (A)	I_{rms} (A)	$P_{br,cont}$ (kW)	P_{br} (kW)	I_{rms} (A)	P_{br} (kW)	I_{rms} (A)	(l/min)	(m ³ /h)	(mm)	(mm)	(mm)					
404	1.35	835	97	54	167	149	287	257	1.6	1840	2002	1200	644	NBRW-669C	2xSAFUR200F500	0400-7		
807	0.68	1670	194	108	333	298	575	514	3.2	4340	2002	2400	644	2xNBRW-669C	2x(2xSAFUR200F500)	0800-7		
1211	0.45	2505	291	162	500	447	862	771	4.8	6180	2002	3600	644	3xNBRW-669C	3x(2xSAFUR200F500)	1200-7		
1615	0.34	3340	388	216	667	596	1150	1028	6.4	8020	2002	4800 ⁴⁾	644	4xNBRW-669C	4x(2xSAFUR200F500)	1600-7		
2019	0.27	4175	485	270	833	745	1437	1285	8.0	9860	2002	6000 ⁴⁾	644	5xNBRW-669C	5x(2xSAFUR200F500)	2000-7		
2422	0.23	5010	582	324	1000	894	1724	1542	9.6	11700	2002	7200 ⁴⁾	644	6xNBRW-669C	6x(2xSAFUR200F500)	2400-7		

¹⁾ Coolant flow rate is for the brake chopper module only.
²⁾ Air flow is for the brake resistor only, which is air-cooled.
³⁾ Power loss conducted to coolant and emitted to air
⁴⁾ Additional 300 mm junction section needed.

Ratings	
Nominal ratings	
P_{brmax}	Maximum short-term (1 min every 10 mins) braking power.
R_{tot}	Total brake resistor resistance of the whole brake unit.
I_{max}	Maximum peak current of the whole brake unit.
I_{rms}	Corresponding rms current per chopper during load cycle.
P_{brcont}	Maximum continuous power rating.
Cyclic load (1 min/5 min)	
P_{br}	Maximum braking power, allowed for 1 minute every 5 minutes.
I_{rms}	Total rms current during a period of 1 minute with braking power P_{br} .
Cyclic load (1 min/5 min)	
P_{br}	Total rms current during a period of 10 seconds with braking power P_{br} .
I_{rms}	Maximum braking power, allowed for 10 seconds every 60 seconds
Losses	
P_{loss}	Power loss conducted to coolant and emitted to air.

ACS880-607LC liquid cooled 3-phase dynamic brake units

$U_N = 690 \text{ V (range 525 to 690 V)}$																			
Resistor values		Ratings R_{min}								Ratings R_{max}								Brake unit type ACS880-607LC-	Frame size
		No-overload use				Duty cycle (1 min/5 min)				No-overload use				Duty cycle (1 min/5 min)					
R_{min} (ohm)	R_{max} (ohm)	I_{dc} DC (A)	I_{rms} DC (A)	P_{cont} (kW)	I_{max} DC (A)	I_{dc} DC (A)	I_{rms} DC (A)	R_{min} DC (A)	P_{br} (kW)	R_{min} (A)	I_{dc} DC (A)	I_{rms} DC (A)	P_{rcont} (kW)	I_{max} DC (A)	I_{dc} DC (A)	I_{rms} DC (A)	R_{min} DC (A)	P_{br} (kW)	R_{min} (A)
3.0	3.6	781	310	870	370	999	351	1110	781	283	870	312	833	293	920	0870-7	R8i		
2.0	2.4	1171	465	1300	555	1499	527	1660	1171	425	1300	468	1249	439	1390	1300-7	R8i		
3.0	3.6	1562	621	1730	740	1998	702	2220	1562	567	1730	625	1665	585	1850	1730-7	2xR8i		
2.0	2.4	2342	931	2600	1110	2997	1053	3330	2342	850	2600	937	2498	878	2770	2600-7	2xR8i		
2.0	2.4	3514	1396	3900	1665	4496	1580	4990	3514	1275	3900	1405	3746	1316	4160	3900-7	3xR8i		
2.0	2.4	4685	1862	5200	2220	5994	2106	6650	4685	1700	5200	1874	4995	1755	5540	5200-7	4xR8i		

Du/dt filters

Du/dt filtering suppresses inverter output voltage spikes and rapid voltage changes that stress motor insulation. Additionally, du/dt filtering reduces capacitive leakage currents and high-frequency emissions from the motor cable, as well as high-frequency losses and bearing currents in the motor. The need for du/dt filtering depends on the motor insulation. For information on the construction of the motor insulation, consult the manufacturer.

If the motor does not meet the following requirements, the lifetime of the motor might decrease. Insulated N-end (non-driven end) bearings and/or common mode filters are also required for motor bearing currents with motors bigger than 100 kW. For more information, please see the ACS880 hardware manuals.

Please see below for information about how to select a filter according to the motor.

Filter selection table for ACS880

Motor type	Nominal AC supply voltage	Motor insulation system	Requirements for		
			ABB du/dt and common mode filters, insulated N-end motor bearings		
			$P_N < 100 \text{ kW}$ and frame size < IEC 315	$100 \text{ kW} \leq P_N < 350 \text{ kW}$ or IEC 315 \leq frame size < IEC 400	$P_N \geq 350 \text{ kW}$ or frame size \geq IEC 400
			$P_N < 134 \text{ hp}$ and frame size < NEMA 500	$134 \text{ hp} \leq P_N < 469 \text{ hp}$ or NEMA 500 \leq frame size \leq NEMA 580	$P_N \geq 469 \text{ hp}$ or frame size \geq NEMA 580
ABB motors					
Random-wound M2__, M3__ and M4__	$U_N \leq 500 \text{ V}$	Standard	–	+ N	+ N + CMF
	$500 \text{ V} < U_N \leq 600 \text{ V}$	Standard	+ du/dt	+ du/dt + N	+ du/dt + N + CMF
		Reinforced	–	+ N	+ N + CMF
	$600 \text{ V} < U_N \leq 690 \text{ V}$ (cable length $\leq 150 \text{ m}$)	Reinforced	+ du/dt	+ du/dt + N	+ du/dt + N + CMF
Reinforced		–	+ N	+ N + CMF	
Form-wound HX__ and AM__	$380 \text{ V} < U_N \leq 690 \text{ V}$	Standard	n/a	+ N + CMF	$P_N < 500 \text{ kW}$: + N + CMF $P_N \geq 500 \text{ kW}$: + du/dt + N + CMF
Old ¹⁾ form-wound HX__ and modular	$380 \text{ V} < U_N \leq 690 \text{ V}$	Check with the motor manufacturer	+ du/dt with voltages over 500 V + N + CMF	+ du/dt with voltages over 500 V + N + CMF	+ du/dt with voltages over 500 V + N + CMF
Random-wound HX__ and AM__ ²⁾	$0 \text{ V} < U_N \leq 500 \text{ V}$	Enamelled wire with fiber glass taping	+ N + CMF	+ N + CMF	+ N + CMF
	$500 \text{ V} < U_N \leq 690 \text{ V}$		+ du/dt + N + CMF	+ du/dt + N + CMF	+ du/dt + N + CMF
HPD	Consult the motor manufacturer.				

¹⁾ Manufactured before 1.1.1998.

²⁾ For motors manufactured before 1.1.1998, check for additional instructions with the motor manufacturer.

Non-ABB motors

Random-wound and form-wound	$U_N \leq 420 \text{ V}$	Standard: $\hat{U}_{LL} = 1300 \text{ V}$	–	+ N or CMF	+ N + CMF
	$420 \text{ V} < U_N \leq 500 \text{ V}$	Standard: $\hat{U}_{LL} = 1300 \text{ V}$	+ du/dt	+ du/dt + N or + du/dt + CMF	+ du/dt + N + CMF
		Reinforced: $\hat{U}_{LL} = 1600 \text{ V}$, 0.2 microsecond rise time	–	+ N or CMF	+ N + CMF
	$500 \text{ V} < U_N \leq 600 \text{ V}$	Reinforced: $\hat{U}_{LL} = 1600 \text{ V}$	+ du/dt	+ du/dt + N or + du/dt + CMF	+ du/dt + N + CMF
		Reinforced: $\hat{U}_{LL} = 1800 \text{ V}$	–	+ N or CMF	+ N + CMF
	$600 \text{ V} < U_N \leq 690 \text{ V}$	Reinforced: $\hat{U}_{LL} = 1800 \text{ V}$	+ du/dt	+ du/dt + N	+ du/dt + N + CMF
		Reinforced: $\hat{U}_{LL} = 2000 \text{ V}$, 0.3 microsecond rise time ³⁾	–	+ N or CMF	+ N + CMF

³⁾ If the intermediate DC circuit voltage of the drive is increased from the nominal level due to long term resistor braking cycles, check with the motor manufacturer if additional output filters are needed in the applied drive operation range.

The abbreviations used in the table are defined below

Abbr.	Definition
U_N	Nominal AC line voltage.
\hat{U}_{LL}	Peak line-to-line voltage at motor terminals which the motor insulation must withstand.
P_N	Motor nominal power.
du/dt	du/dt filter at the output of the drive. Available from ABB as an optional add-on kit.
CMF	Common mode filter. Depending on the drive type, CMF is available from ABB as a factory-installed option (+208) or as an optional add-on kit.
N	N-end bearing: insulated motor non-drive end bearing.
n/a	Motors of this power range are not available as standard units. Consult the motor manufacturer.

Du/dt filters

External du/dt filter for ACS880-107						
ACS880-107						
400 V	500 V	690 V	NOCH0016-60	NOCH0030-60	NOCH0070-60	BOCH-0350A-7
004A8-3	003A6-5	007A3-7	x			
006A0-3	004A8-5	009A8-7	x			
008A0-3	006A0-5	014A2-7	x			
0011A-3	008A0-5		x			
0014A-3	0011A-5		x			
0018A-3	0014A-5		x			
	0018A-5		x			
0025A-3	0025A-5	0018A-7		x		
0030A-5		0022A-7		x		
0035A-3	0035A-5	0027A-7		x		
0044A-3		0035A-7			x	
0050A-3	0050A-5	0042A-7			x	
0061A-3	0061A-5	0052A-7			x	
0078A-3	0078A-5				x	
0094A-3	0094A-5				x	
0100A-3					x	
0140A-3	0110A-5	0062A-7				x
0170A-3	0140A-5	0082A-7				x
0210A-3	0170A-5	0100A-7				x
0250A-3	0200A-5	0130A-7				x
0300A-3	0240A-5	0140A-7				x
0350A-3	0300A-5	0190A-7				x
	0340A-5	0220A-7				x
		0270A-7				x

All parallel connected ACS880-104 modules in frame size nxR8i and all 690 V ACS880-104/107LC modules in frame size 1xR8i and nxR8i have du/dt filters built-in as standard (+E205).

Built-in du/dt filters are available as option (+E205) for ACS880-104 modules in frame size 1xR8i ranging from 380 to 500 V. The built-in du/dt filters in R8i modules do not impact the module dimensions.

Dimensions and weights of the du/dt filters				
du/dt filter	Height (mm)	Width (mm)	Depth (mm)	Weight (kg)
BOCH-0350A-7 ²⁾	310	347	256	16
NOCH0016-60	195	140	115	2.4
NOCH0016-62/65	323	199	154	6
NOCH0030-60	215	165	130	4.7
NOCH0030-62/65	348	249	172	9
NOCH0070-60	261	180	150	9.5
NOCH0070-62/65	433	279	202	15.5
NOCH0120-60 ¹⁾	200	154	106	7
NOCH0120-62/65	765	308	256	45
FOCH0260-70	382	340	254	47
FOCH0260-72	900	314	384	73
FOCH0320-50	662	319	293	65
FOCH0320-52	1092	396	413	100
FOCH0610-70	662	319	293	65
FOCH0875-70	662	319	293	65

¹⁾ 3 filters included, dimensions apply to one filter.

²⁾ Values are for three single-phase filters.

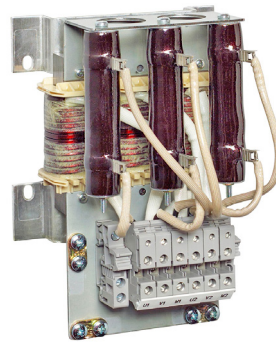

NOCH0016-60

ACS880 drives are compatible with the wide ABB product offering



Programmable Logic Controllers PLCs

The AC500, AC500-eCo, AC500-S and AC500-XC scalable PLC ranges provide solutions for small, medium and high-end applications. Our AC500 PLC platform offers different performance levels and is the ideal choice for high availability, extreme environments, condition monitoring, motion control or safety solutions.



AC motors

ABB's low voltage AC motors are designed to save energy, reduce operating costs and minimize unscheduled downtime. General performance motors ensure convenience, while process performance motors provide a broad set of motors for the process industries and heavy-duty applications.



Control panels

CP600-eCo, CP600 and CP600-Pro control panels offer a wide range of features and functionalities for maximum operability. ABB control panels are distinguished by their robustness and easy usability, providing all the relevant information from production plants and machines at one single touch.



All-compatible drives portfolio

The all-compatible drives share the same architecture; software platform, tools, user interfaces and options. Yet, there is an optimal drive from the smallest water pump to the biggest cement kiln, and everything in between.



Safety products

ABB safety products are helping machine builders to create production-friendly and safe work environments for operators. We deliver machine safety solutions for single machines or entire production lines. Our long experience of helping customers making solutions for demanding environments has made us experts in combining production demands with safety demands for production-friendly solutions.

Choose the right motor for your application

High Dynamic Performance (HDP) motors with ACS880 drives

ABB's HDP motors are offered in frame sizes 80 to 400 up to megawatt-class, with water-cooled and high-speed variants available in selected frame sizes. ABB's HDP motors have a very high power density, which means that they provide more power to the machine applications than conventional machine motors. ABB's HDP motors are the optimal solution for high-torque machine applications such as extruders, cranes, test benches, etc.

ABB HDP motors are always used with a drive. To make full use of ABB's VSDs – including flexibility to optimize processes and control, reliability to reduce downtime, and efficiency to reduce energy use and carbon emissions – the motor's technology solution must be up to the challenge. ABB's HDP motors are designed to enable fast motion control and high maneuvering precision due to their low inertia and high overload capacity.

Induction motors and the ACS880: a reliable combination

Induction motors are used throughout industry in applications that demand robust and high enclosure motor and drive solutions. ACS880 drives fit perfectly together with this type of motor by providing comprehensive functionality, yet simple operation. The drives are ideal for environments that require a high degree of protection and small footprint. ACS880 drives come with DTC as standard, ensuring high-speed accuracy. Our motors and drives provide the perfect foundation for energy efficiency, while delivering capabilities such as exceeding the nominal motor speed when maximum power is needed.

Our low voltage motors for explosive atmospheres and low voltage industrial drives have been tested and certified to verify that, when correctly dimensioned, they are safe to use in explosive atmospheres. ABB drives can also be used with non-ABB Ex motors with ATEX-certified thermistor protection. If this protection is not used, the motor and drive combination must be either type-tested or combined-tested for potentially explosive atmospheres by the

customer, motor manufacturer or a third party. It is also important to verify that the motor can be used with ABB variable speed drives.

Permanent magnet motors and the ACS880: smooth operation

Permanent magnet technology is used for improved motor characteristics in terms of energy efficiency and compactness. This technology is particularly well-suited for low-speed control applications, as in some cases it eliminates the need to use gearboxes. The actual characteristics of different permanent magnet motors can vary considerably. Even without speed or rotor position sensors, ACS880 drives with DTC can control most types of permanent magnet motors.

Externally exited synchronous machines

The ACS880 externally exited synchronous machine control is an option for ACS880 multidrive inverter unit offering in R8i based frames. The main difference between ACS880 externally exited synchronous machine control and other machine control modes is the rotor current, which in ACS880 externally exited synchronous machine control is supplied to rotor from excitation unit EXU through brushes.

Variable speed synchronous motors are often used in demanding applications where variable speed delivers clear benefits. Rolling mills, mine hoists, pumps, extruders, compressors and main propulsion system in ships are typical examples of variable speed applications. ACS880 inverter unit has ordering option (+N8052) for excitation unit which monitors and controls the excitation of the synchronous motor.

IE5 Synchronous reluctance motors and the ACS880: optimized energy efficiency

Combining the ACS880's control technology with our Synchronous reluctance (SynRM) motors provides an IE5 motor and drive package that ensures high energy efficiency, reduces motor temperatures and provides a significant reduction in motor noise. Lower temperature results in better motor reliability and longer motor life.

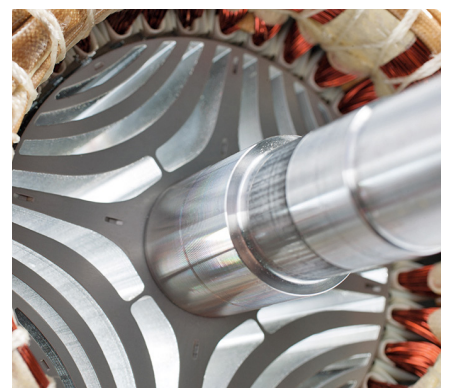
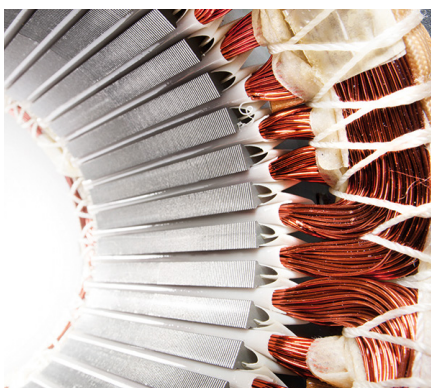

Synchronous reluctance motors

Ultimate efficiency and reliability to optimize your cost of ownership

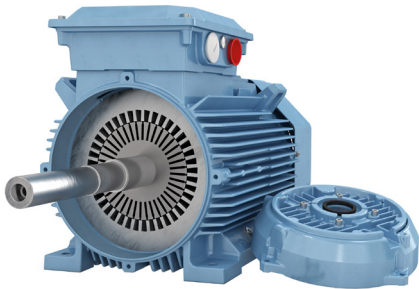

Traditional induction motor

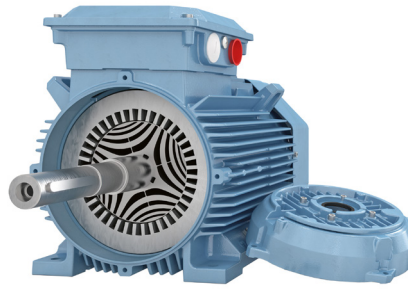

IE5 SynRM motor

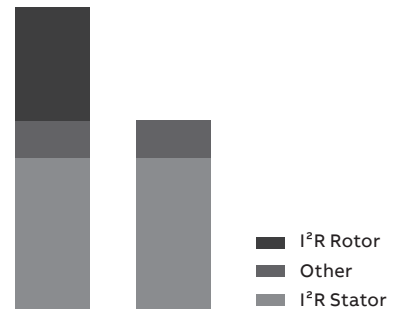

Losses IM vs SynRM

Innovation inside

The idea is simple. Take a conventional, proven stator technology and an innovative rotor design. Then combine them with an ABB machinery drive loaded with software with versatile features. Finally, optimize the whole package for applications such as compressors, conveyors, pumps, extruders, fans and many other variable and constant torque applications.

Magnet-free design

Synchronous reluctance technology combines the performance of a permanent magnet motor with the simplicity and service-friendliness of an induction motor. The new rotor has neither magnets nor windings, and suffers virtually no power losses. And because there are no magnetic forces in the rotor, maintenance is as straightforward as with induction motors.

Superior reliability to minimize the cost of not running

International Efficiency class IE5 Synchronous reluctance motors (SynRM) have very low winding temperatures, which increases the reliability and lifetime of the winding. More importantly, a cool synchronous reluctance rotor means significantly lower bearing temperatures – an important factor because bearing failures cause about 70 percent of unplanned motor outages.

Perfect for retrofits

The SynRM package is a perfect solution for motor retrofits. The IE5 SynRM is the same size as an IE3 induction motor, eliminating the need for mechanical modifications. The increased efficiency will, on the other hand, reduce the payback time of the investment.

Full motor control, down to zero speed

Many processes require accurate speed control. SynRM always runs at reference speed with practically no error, without an encoder. Even the best slip compensation systems in an induction motor inverter will never match the precision of SynRM. Sometimes your application may require you to run your motor at slow speeds. If you are using SynRM and your drive cannot provide the necessary torque, it may trip. ABB drives provide full control and torque down to zero speed, even without speed sensors.

For all applications

This is important if you are planning on using the motor with applications other than quadratic torque applications like pumps and fans. Our drives provide full SynRM motor control for constant torque applications such as extruders, conveyors and wire drawing machines.

SynRM technology	Benefit
Higher efficiency IE5	Lowest energy consumption
No rare earth metals	Environmental sustainability
Magnet-free rotor	Easy service
Lower winding and bearing temperatures	Longer life time, extended service intervals
Better controllability	Accurate speed and torque control
Lower noise level	Better working and living environment
Same size with IE3	Perfect for retrofits



K

Our service expertise, your advantage

ABB Motion Services helps customers around the globe by maximizing uptime, extending product life cycle, and enhancing the performance and energy efficiency of electrical motion solutions. We enable innovation and success through digitalization by securely connecting and monitoring our customers' motors and drives, increasing operational uptime, and improving efficiency. We make the difference for our customers and partners every day by keeping their operations running profitably, safely and reliably.

With a service offering tailored to your needs, ABB Motion Services maximizes the uptime and extends the life cycle of your electrical motion solutions, while optimizing their performance and maximizing your energy efficiency gains throughout the entire lifetime of your applications. We help to keep your applications turning profitably, safely, and reliably.

Digitalization enables new smart and secured ways to prevent unexpected downtime while optimizing the operation and maintenance of your assets. We securely connect and monitor your motors, drives or your entire powertrain to our easy-to-use cloud service solutions. Connecting your applications also gives you access to our in-depth service domain expertise.

We quickly respond to your service needs. Together with our partners, local field service experts, and service workshop networks, we provide and install original spare parts to help resolve any issues and minimize the impact of unexpected disruptions.

Our tailored to your needs service offerings and digital solutions will enable you to unlock new possibilities. Not only are we your premier supplier of motion equipment, we are your trusted partner and advisor offering support throughout the entire life cycle of your assets. We ensure your operations run profitably, safely and reliably and continue to drive real world results, now and in the future. Our service teams work with you, delivering the expertise needed to keep your world turning while saving energy every day.



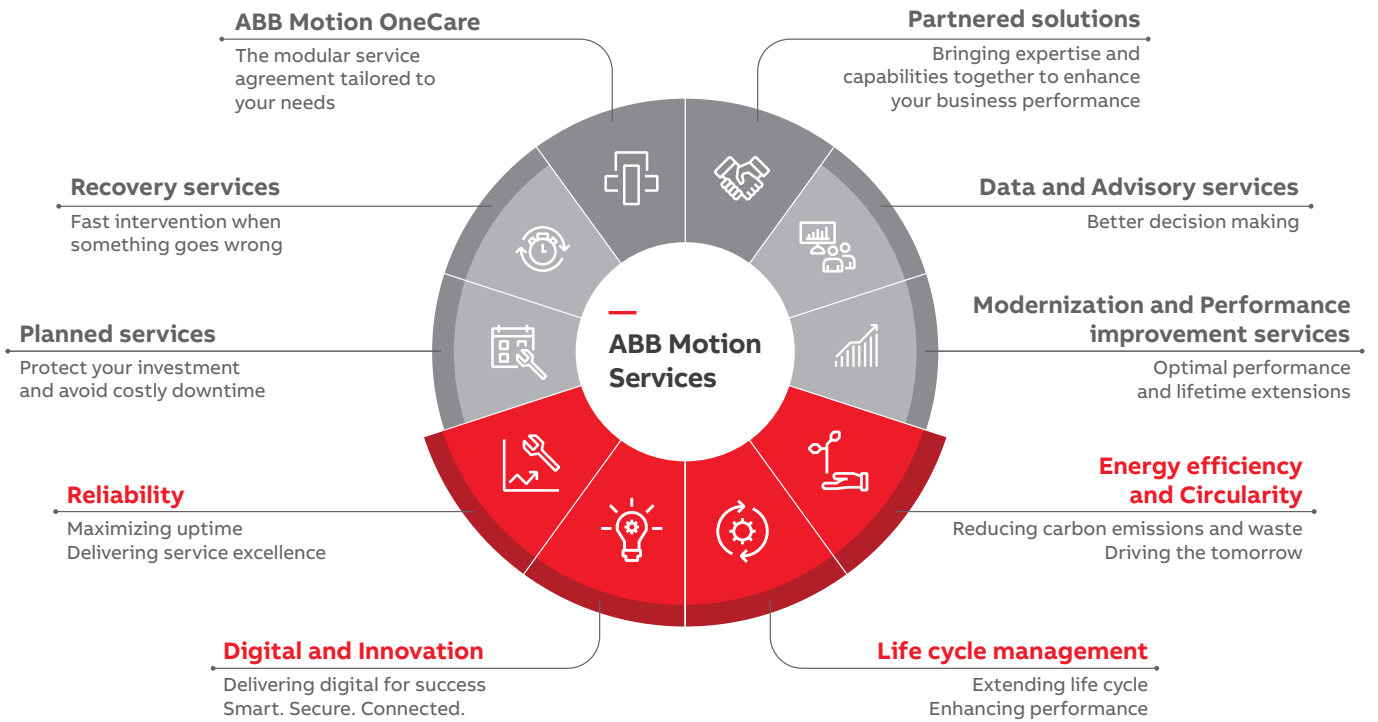

OUR EXPERTISE
YOUR ADVANTAGE



ABB Ability™ Mobile Connect for drives

Easy access to remote support

ABB Ability™ Mobile Connect for drives is a platform for remote drive support consisting of the Mobile Connect web portal and the Drivetune mobile app.

The platform allows ABB service partners to provide remote commissioning and troubleshooting support for personnel on-site without any complex connectivity infrastructure. Chats, sharing images and backups, viewing parameters online and sending support packages

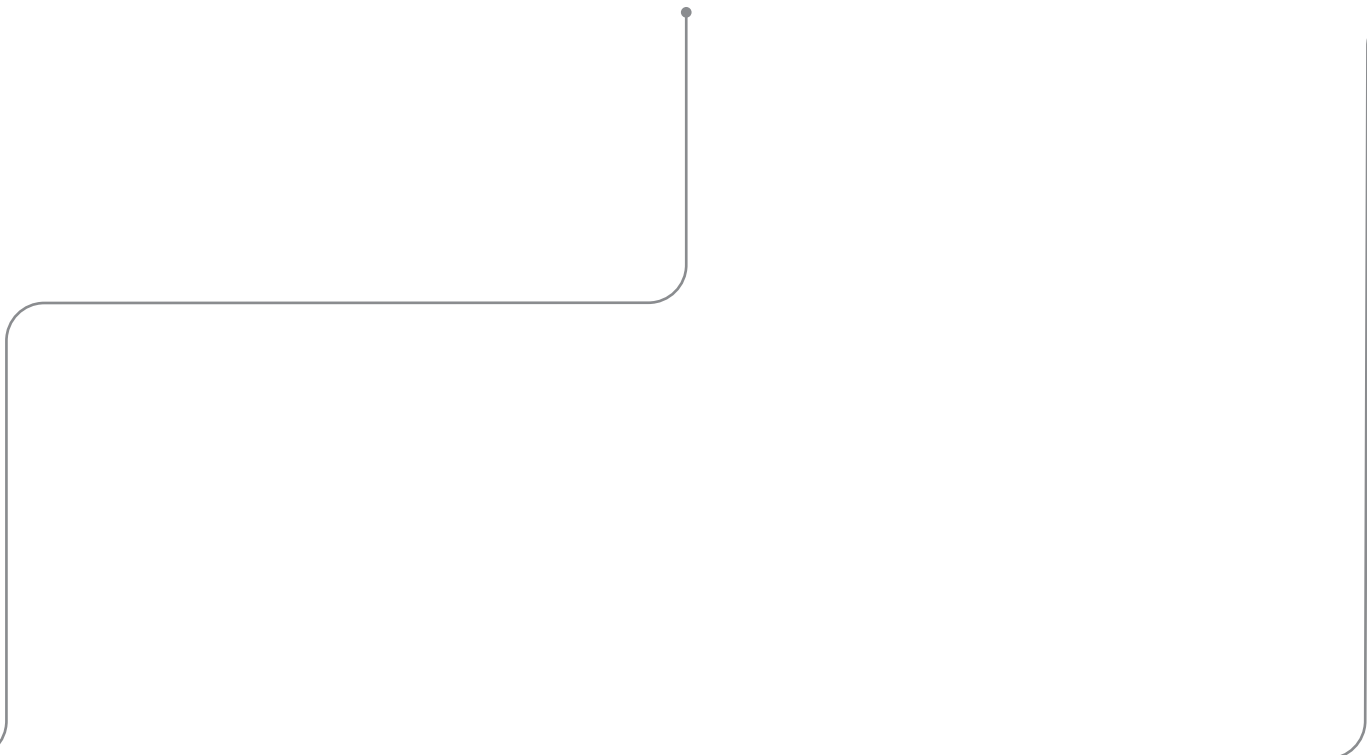
are all possible, making your technical support process quick and efficient.

All that is needed is the Bluetooth control panel and a mobile device.

The platform is available for ABB partners and OEMs under a renewable subscription-based agreement.

[ABB Ability™ Mobile Connect for drives support portal](#)

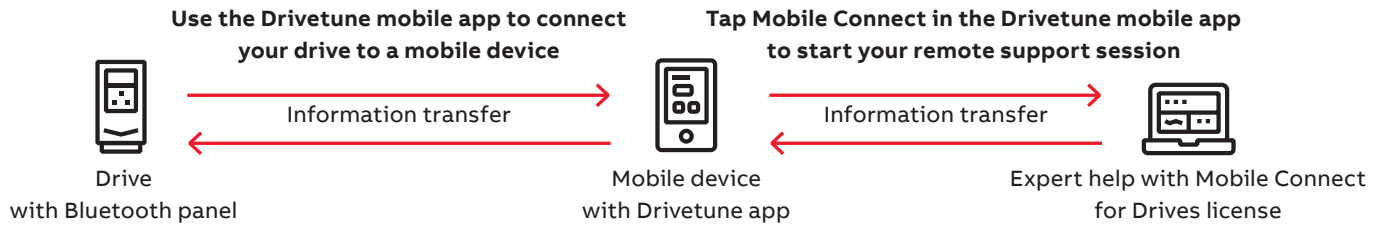

Drivetune mobile app for managing drives via an intuitive interface

Drivetune mobile app is a powerful tool for performing basic drive startup and troubleshooting tasks. It is possible to connect with drives and access data available in the Internet at the same time. The wireless Bluetooth

connectivity means that users won't need to enter hazardous or difficult-to-reach work areas to access information necessary to help them commission and tune the drive.



- **Startup, commission and tune your drive and application with full parameter access**
- **Optimize performance via drive troubleshooting features**
- **Create and share backups and support packages**
- **Keep track of drives installed base**

Download Drivetune mobile app



Summary of features and options

ACS880 air-cooled multidrivess

Option code	ACS880 -107 INU R1i to nxR8i	ACS880 -207 ISU nxR8i	ACS880 -307 DSU D6D to D8D 6-pulse	ACS880 -307 DSU D7T and nxD8T 6 or 12-pulse	ACS880 -907 RRU nxR8i	ACS880 -607 brake unit nxR8i	ACS880 -1607 DC/DC nxR8i
Mounting							
Free-standing	●	●	●	●	●	●	●
Cabling							
Supply bottom entry	–	●	●	●	●	–	–
Supply top entry	–	□	□	□	□	–	–
Inverter bottom exit	●	–	–	–	–	●	●
Inverter top exit	□	–	–	–	–	□	□
Degree of protection							
IP22 (UL type 1)	●	●	●	●	●	●	●
IP42 (UL type 1)	□	□	□	□	□	□ ¹⁾	□ ¹⁾
IP54 (UL type 12)	□	□	□	□	□	□ ¹⁾	□ ¹⁾
Motor control							
DTC motor control	●	–	–	–	–	–	–
Control panel							
Intuitive control panel	□	□	□	□	□	□ ²⁾	□
EMC filters							
EMC 1st environment, restricted distribution, C2, grounded network (TN)	+E202	–	□	–	□ ⁴⁾	–	–
EMC 2nd environment, C3, grounded (TN) and ungrounded network (IT)	+E210	□ ⁵⁾	□ ⁵⁾	□ ⁵⁾	□ ⁵⁾	□ ⁵⁾	□ ⁵⁾
Line filter							
AC or DC choke	–	–	●	●	–	–	–
Advanced line harmonic filter LCL	–	●	–	–	–	–	–
Advanced line harmonic filter L	–	–	–	–	●	–	–
Output filter							
Common mode filter	+E208	● ⁶⁾	● ⁶⁾	–	–	● ⁶⁾	●
Du/dt filters	+E205	● ⁷⁾	●	–	–	●	●
Braking (see braking unit table)							
Incoming unit apparatus							
Disconnecter	–	● ⁸⁾	●	● ⁹⁾	● ¹⁰⁾	–	–
Air circuit breaker	+F255	–	● ¹¹⁾	●	● ⁹⁾	● ¹²⁾	–
Line contactor	+F250	–	● ⁸⁾	□	–	● ¹⁰⁾	–
Earthing switch	+F259	–	□	□	□	□	–
Inverter units							
DC switch	+F286	□ ¹³⁾	–	–	–	–	□ ¹⁴⁾
R1i - R5i in an own compartment	+C204	□	–	–	–	–	–

- Standard
- Selectable option, with plus code
- Selectable option, external, no plus code

ACS880 air-cooled multidrives

	Option code	ACS880 -107 INU R1i to nxR8i	ACS880 -207 ISU nxR8i	ACS880 -307 DSU D6D to D8D 6-pulse	ACS880 -307 DSU D7T and nxD8T 6 or 12-pulse	ACS880 -907 RRU nxR8i	ACS880 -607 brake unit nxR8i	ACS880 -1607 DC/DC nxR8i
Software								
Primary control program		●	–	–	–	–	–	–
Drive application programming based on IEC 61131-3 using Drive Application Builder (available for primary control program)	+N8010	□ ³⁾	□ ³⁾	–	–	–	–	–
Application control program for winder	+N5000	□	–	–	–	–	–	–
Application control program for crane	+N5050	□	–	–	–	–	–	–
Application control program for winch	+N5100	□	–	–	–	–	–	–
Application control program for centrifuge/decanter	+N5150	□	–	–	–	–	–	–
Application control program for PCP pump	+N5200	□	–	–	–	–	–	–
Application control program for test bench	+N5300	□	–	–	–	–	–	–
High speed test bench ²⁵⁾	+P967	□	–	–	–	–	–	–
Application control program for override control	+N5450	□	–	–	–	–	–	–
Application control program for ESP pumps	+N5600	□	–	–	–	–	–	–
Application control program for position control	+N5700	□ ²⁴⁾	–	–	–	–	–	–
Support for asynchronous motor		●	–	–	–	–	–	–
Support for permanent magnet motor		●	–	–	–	–	–	–
Support for Synchronous reluctance motor (SynRM)	+N7502	□	–	–	–	–	–	–
Application control program for LV synchronous machine	+N8052	□	–	–	–	–	–	–
Optimal grid control of IGBT supply control program (grid converter)	+N8053	–	□	–	–	–	–	–
High speed license. Allows high speed operation above 598 Hz output frequency.	+N8200	□	–	–	–	–	–	–
Approvals								
CE, UKCA		●	●	●	●	●	●	●
UL, cUL		□	□	□	□	□	□	□
CSA		□	□	□	□	□	□	□
EAC/GOST R ¹⁵⁾		●	●	●	●	●	●	●
RoHS		●	●	●	●	●	●	●
RCM		●	●	●	●	●	●	●
Marine type approvals ¹⁶⁾	+C132	□ ¹⁷⁾	□	–	□	–	□	□
TÜV nord certificate for STO		●	–	–	–	–	–	–
TÜV nord certificate for FSO-12	+Q973	□	–	–	–	–	–	–
TÜV nord certificate for FSO-21	+Q972	□	–	–	–	–	–	–
TÜV nord certificate for FSE-31	+L521	□	–	–	–	–	–	–
Eurofins ATEX protective device certificate	+Q971 +L513/ +L514 or +Q971 +L537	□	–	–	–	–	–	–
SEMI F47		●	●	●	●	●	●	●

● Standard

□ Selectable option, with plus code

■ Selectable option, external, no plus code

ACS880 air-cooled multidrives

	Option code	ACS880 -107 INU R1i to nxR8i	ACS880 -207 ISU nxR8i	ACS880 -307 DSU D6D to D8D 6-pulse	ACS880 -307 DSU D7T and nxD8T 6 or 12- pulse	ACS880 -907 RRU nxR8i	ACS880 -607 brake unit nxR8i	ACS880 -1607 DC/DC nxR8i
Safety functions ²³⁾								
Safe Torque Off (STO)		●	-	-	-	-	-	-
Safety functions module, FSO-12, without encoder, configurable functions: - Safe Stop 1 (SS1-t, SS1-r) - Safely-Limited Speed (SLS) - Safe Brake Control (SBC) - Safe Maximum Speed (SMS) - Safe Stop Emergency (SSE) - Prevention Of Unexpected Start-up (POUS) - Safe Torque Off (STO)	+Q973	□	-	-	-	-	-	-
Safety functions module, FSO-21, with encoder support, configurable functions: - Safe Stop 1 (SS1-t, SS1-r) - Safely-Limited Speed (SLS) - Safe Brake Control (SBC) - Safe Maximum Speed (SMS) - Safe Stop Emergency (SSE) - Prevention Of Unexpected Start-up (POUS) - Safe Direction (SDI), requires encoder feedback, FSE-31 - Safe Speed Monitoring (SSM) - Safe Torque Off (STO)	+Q972	□	-	-	-	-	-	-
Pulse encoder interface module, FSE-31	+L521	□	-	-	-	-	-	-
Prevention of unexpected start-up with safety relay(s)	+Q957	□	-	-	-	-	-	-
Prevention of unexpected start-up with STO and safety functions module (FSO-12/-21)	+Q950 +Q973/ +Q972	□	-	-	-	-	-	-
Emergency stop, category 0 with opening the main contactor/breaker, with safety relay	+Q951	-	□	□	□	□	-	-
Emergency stop, category 1 with opening the main contactor/breaker, with safety relay	+Q952	-	□	□	□	□	-	-
Emergency stop, category 0 with STO, with safety relay	+Q963	-	□	□	□	□	-	-
Emergency stop, category 1 with STO, with safety relay	+Q964	-	□	□	□	□	-	-
Emergency stop, configurable category 0 or 1 with STO and safety functions module (FSO-12/-21)	+Q979 +Q973/ +Q972	-	□	□	□	□	-	-
PROFIsafe over PROFINET with safety functions module (FSO-21) and FPNO-21	+Q982 +Q972 +K492	□	-	-	-	-	-	-
Safely-Limited Speed (SLS) without encoder with FSO-12/-21 (encoderless)	+Q966 +Q973 +Q972	□	-	-	-	-	-	-
Safely-Limited Speed (SLS) with FSO-21 and encoder FSE-31	+Q965 +Q972 +L521	□	-	-	-	-	-	-
ATEX thermal motor protection for PTC/PT100, EX II (2) GD	+Q971 +L513/ +L514	□	-	-	-	-	-	-
FPTC-01 thermistor protection module	+L536	□	-	-	-	-	-	-
ATEX certified thermistor protection module, FPTC-02, EX II (2) GD	+L537 +Q971	□	-	-	-	-	-	-

● Standard

□ Selectable option, with plus code

■ Selectable option, external, no plus code

ACS880 air-cooled multidrives

	Option code	ACS880 -107 INU R1i to nxR8i	ACS880 -207 ISU nxR8i	ACS880 -307 DSU D6D to D8D 6-pulse	ACS880 -307 DSU D7T and nxD8T 6 or 12-pulse	ACS880 -907 RRU nxR8i	ACS880 -607 brake unit nxR8i	ACS880 -1607 DC/DC nxR8i
Earth fault protection								
Earth fault monitoring, earthed mains		●	●	–	–	●	–	–
Earth fault monitoring, unearthed mains	+Q954	–	□	□	□	□	–	–
Control connections (I/O) and communications								
2 pcs analog inputs, programmable, galvanically isolated		●	●	●	●	●	● ²⁾	●
2 pcs analog outputs, programmable		●	●	●	●	●	● ²⁾	●
6 pcs digital inputs, programmable, galvanically isolated – can be divided into two groups		●	●	●	●	●	● ²⁾	●
2 pcs digital inputs/outputs		●	●	●	●	●	● ²⁾	●
1 pcs digital input interlock		●	●	●	●	●	● ²⁾	●
3 pcs relay outputs		●	●	●	●	●	● ²⁾	●
Drive-to-drive link/Built-in Modbus		●	–	–	–	–	–	–
Assistant control panel/PC tool connection		●	●	●	●	●	● ²⁾	●
Possibility for external power supply for control unit		□	□	□	□	□	□ ²⁾	□
Built-in I/O extension and speed feedback modules: for more details see sections: "Input/output extension modules", "Speed feedback interfaces for precise process control" and "DDCS communication option modules" ¹⁸⁾		□	□	□	□	□	□ ²⁾	□
Built-in adapters for several communication protocols: for more details see section "Communication protocol adapters" ¹⁹⁾		□	□	□	□	□	□ ²⁾	□

- Standard
- Selectable option, with plus code
- Selectable option, external, no plus code

ACS880 liquid-cooled multidrives

	Option code	ACS880 -107LC INU R7i, nxR8i	ACS880 -207LC ISU R7i, nxR8i	ACS880 -307LC DSU nxD8T	ACS880 -607LC brake unit	ACS880 -1607LC DC/DC nxR8i
Mounting						
Free-standing		●	●	●	●	●
Cabling						
Supply bottom entry		–	●	●	–	–
Supply top entry		–	□	□	–	–
Inverter bottom exit		●	–	–	●	●
Inverter top exit		□	–	–	□	□
Degree of protection						
IP22 (UL type 1)		–	–	–	–	–
IP42 (UL type 1)		●	●	●	●	●
IP54 (UL type 12)		□	□	□	□	□
Motor control						
DTC motor control		●	–	–	–	–
Control panel						
Intuitive control panel		□	□	□	□ ²⁾	□
EMC filters						
EMC 1st environment, restricted distribution, C2, grounded network (TN)	+E202	–	□	□	–	–
EMC 2nd environment, C3, grounded (TN) and ungrounded network (IT)	+E210	□ ⁵⁾	□ ⁵⁾	□ ⁵⁾	□ ⁵⁾	□ ⁵⁾
Line filter						
AC or DC choke		–	–	●	–	–
Advanced line harmonic filter LCL		–	●	–	–	–
Advanced line harmonic filter L		–	–	–	–	–
Output filter						
Common mode filter	+E208	●	●	–	●	●
Du/dt filters	+E205	●	●	–	●	●
Braking (see braking unit table)						
Incoming unit apparatus						
Disconnecter		–	–	–	–	–
Air circuit breaker	+F255	–	● ²⁶⁾	●	–	–
Line contactor	+F250	–	–	–	–	–
Earthing switch	+F259	–	□	□	–	–
Inverter units						
DC switch	+F286	□	□	–	□ ¹⁴⁾	□
R1i - R5i in an own compartment	+C204	–	–	–	–	–

● Standard

□ Selectable option, with plus code

■ Selectable option, external, no plus code

ACS880 liquid-cooled multidrives

	Option code	ACS880 -107LC INU R7i, nxR8i	ACS880 -207LC ISU R7i, nxR8	ACS880 -307LC DSU nxD8T	ACS880 -607LC brake unit	ACS880 -1607LC DC/DC R7i, nxR8i
Software						
Primary control program		●	–	–	–	–
Drive application programming based on IEC 61131-3 using Drive Application Builder (available for primary control program)	+N8010	□ ³⁾	□ ³⁾	–	–	–
Application control program for winder	+N5000	□ ²⁷⁾	–	–	–	–
Application control program for crane	+N5050	□ ²⁸⁾	–	–	–	–
Application control program for winch	+N5100	□ ²⁷⁾	–	–	–	–
Application control program for centrifuge/decanter	+N5150 ¹⁾	□ ²⁷⁾	–	–	–	–
Application control program for PCP pump	+N5200	□ ²⁷⁾	–	–	–	–
Application control program for test bench	+N5300 ²⁸⁾	□ ²⁸⁾	–	–	–	–
Application control program for override control	+N5450	□ ²⁷⁾	□	□	–	–
Application control program for ESP pumps	+N5600	□ ²⁷⁾	–	–	–	–
Application control program for position control	+N5700	□ ²⁴⁾	–	–	–	–
Support for asynchronous motor		● ²⁷⁾	–	–	–	–
Support for permanent magnet motor		● ²⁷⁾	–	–	–	–
Support for Synchronous reluctance motor (SynRM)	+N7502	□	–	–	–	–
Application control program for LV synchronous machine	+N8052	□ ²⁷⁾	–	–	–	–
Optimal grid control of IGBT supply control program (grid converter)	+N8053	–	□ ²⁷⁾	–	–	–
High speed license. Allows high speed operation above 598 Hz output frequency.	+N8200	□	–	–	–	–
Approvals						
CE, UKCA		●	●	●	●	●
UL, cUL		□	□	□	□	–
CSA		□	□	□	□	–
EAC/GOST R ¹⁵⁾		●	●	●	●	●
RoHS		●	●	●	●	●
RCM		●	●	●	●	●
Marine type approvals ¹⁶⁾	+C132	□	□	□ ³⁾	□ ³⁾	□
TÜV nord certificate for STO		●	–	–	–	–
TÜV nord certificate for FSO-12	+Q973	□	–	–	–	–
TÜV nord certificate for FSO-21	+Q972	□	–	–	–	–
TÜV nord certificate for FSE-31	+L521	□	–	–	–	–
Eurofins ATEX protective device certificate	+Q971 +L513/ +L514 or +Q971 +L537	□	–	–	–	–
SEMI F47		●	●	●	●	●

● Standard

□ Selectable option, with plus code

■ Selectable option, external, no plus code

ACS880 liquid-cooled multidrives

	Option code	ACS880 -107LC INU R7i, nxR8i	ACS880 -207LC ISU R7i, nxR8	ACS880 -307LC DSU nxD8T	ACS880 -607LC brake unit	ACS880 -1607LC DC/DC R7i, nxR8i
Safety functions ²³⁾						
Safe Torque Off (STO)		●	–	–	–	–
Safety functions module, FSO-12, without encoder, configurable functions:						
- Safe Stop 1 (SS1-t, SS1-r)						
- Safely-Limited Speed (SLS)						
- Safe Brake Control (SBC)	+Q973	□	–	–	–	–
- Safe Maximum Speed (SMS)						
- Safe Stop Emergency (SSE)						
- Prevention Of Unexpected Start-up (POUS)						
- Safe Torque Off (STO)						
Safety functions module, FSO-21, with encoder support, configurable functions:						
- Safe Stop 1 (SS1-t, SS1-r)						
- Safely-Limited Speed (SLS)						
- Safe Brake Control (SBC)						
- Safe Maximum Speed (SMS)	+Q972	□	–	–	–	–
- Safe Stop Emergency (SSE)						
- Prevention Of Unexpected Start-up (POUS)						
- Safe Direction (SDI), requires encoder feedback, FSE-31						
- Safe Speed Monitoring (SSM)						
- Safe Torque Off (STO)						
Pulse encoder interface module, FSE-31	+L521	□	–	–	–	–
Prevention of unexpected start-up with safety relay(s)	+Q957	□	–	–	–	–
Prevention of unexpected start-up with STO and safety functions module (FSO-12/-21)	+Q950 +Q973/ +Q972	□	–	–	–	–
Emergency stop, category 0 with opening the main contactor/breaker, with safety relay	+Q951	–	□	□	–	–
Emergency stop, category 1 with opening the main contactor/breaker, with safety relay	+Q952	–	□	□	–	–
Emergency stop, category 0 with STO, with safety relay	+Q963	–	□	□	–	–
Emergency stop, category 1 with STO, with safety relay	+Q964	–	□	□	–	–
Emergency stop, configurable category 0 or 1 with STO and safety functions module (FSO-12/-21)	+Q979 +Q973/ +Q972	–	□ ²⁸⁾	□ ²⁸⁾	–	–
PROFIsafe over PROFINET with safety functions module (FSO-21) and FPNO-21	+Q982 +Q972 +K492	□	–	–	–	–
CIP Safety functions module, FSCS-21	+Q989					
Safely-Limited Speed (SLS) without encoder with FSO-12/-21 (encoderless)	+Q966 +Q973 +Q972	□	–	–	–	–
Safely-Limited Speed (SLS) with FSO-21 and encoder FSE-31	+Q965 +Q972 +L521	□	–	–	–	–
ATEX thermal motor protection for PTC/PT100, EX II (2) GD	+Q971 +L513/ +L514	□	–	–	–	–
FPTC-01 thermistor protection module	+L536	□	–	–	–	–
ATEX certified thermistor protection module, FPTC-02, EX II (2) GD	+L537 +Q971	□	–	–	–	–

● Standard

□ Selectable option, with plus code

■ Selectable option, external, no plus code

ACS880 liquid-cooled multidrives

	Option code	ACS880 -107LC INU R7i, nxR8i	ACS880 -207LC ISU R7i, nxR8	ACS880 -307LC DSU nxD8T	ACS880 -607LC brake unit	ACS880 -1607LC DC/DC nxR8i
Earth fault protection						
Earth fault monitoring, earthed mains		●	●	●	–	–
Earth fault monitoring, unearthed mains	+Q954	–	□	□	–	–
Control connections (I/O) and communications						
2 pcs analog inputs, programmable, galvanically isolated		●	●	●	● ²⁾	●
2 pcs analog outputs, programmable		●	●	●	● ²⁾	●
6 pcs digital inputs, programmable, galvanically isolated – can be divided into two groups		●	●	●	● ²⁾	●
2 pcs digital inputs/outputs		●	●	●	● ²⁾	●
1 pcs digital input interlock		●	●	●	● ²⁾	●
3 pcs relay outputs		●	●	●	● ²⁾	●
Drive-to-drive link/Built-in Modbus		●	–	–	–	–
Assistant control panel/PC tool connection		●	●	●	● ²⁾	●
Possibility for external power supply for control unit		□	□	□	□ ²⁾	□
Built-in I/O extension and speed feedback modules: for more details see sections: “Input/output extension modules”, “Speed feedback interfaces for precise process control” and “DDCS communication option modules” ¹⁸⁾		□	□	□	□ ²⁾	□
Built-in adapters for several communication protocols: for more details see section “Communication protocol adapters” ¹⁹⁾		□	□	□	□ ²⁾	□

● Standard

□ Selectable option, with plus code

■ Selectable option, external, no plus code

– Not available

¹⁾ Not available for resistor D151

²⁾ Not available for 1-phase brake unit

³⁾ Pending

⁴⁾ Available only as 6-pulse D8T

⁵⁾ Conducted emission and immunity are fulfilled with standard filtering. Radiated emission and immunity are as option (cabinet construction).

⁶⁾ Standard for frame sizes R6i to 10×R8i

⁷⁾ Optional in frame sizes R1i to R8i and 400/500 V

⁸⁾ For ISU: 400 to 500 V disconnecter and contactor up to 2×R8i, 690 V disconnecter and contactor up to 3×R8i.

For bigger ISU frames: air-circuit breaker.

⁹⁾ For DSU 6-pulse, 400/500 V: disconnecter up to 3×D8T, air-circuit breaker ≥ 4×D8T.

For DSU 6-pulse, 690 V: disconnecter up to 4×D8T, air-circuit breaker ≥ 5×D8T.

For DSU 12-pulse: All 12-pulse DSUs have disconnecter as standard, air-circuit breaker is offered as an option.

¹⁰⁾ For RRU: Disconnecter and contactor up to 2×R8i, air-circuit breaker ≥ 4×R8i.

¹¹⁾ For ISU: 400 to 500 V air circuit breaker ≥ 3×R8i, 690 V air-circuit breaker ≥ 4×R8i

¹²⁾ For RRU: air circuit breaker >4×R8i

¹³⁾ R1i to R4i for cabinet, individual for R6i to n×R8i. Common for cabinet for R1i to R5i, individual for R6i to n×R8i.

¹⁴⁾ DC switch for 3-phase dynamic brake unit only

¹⁵⁾ EAC has replaced GOST R

¹⁶⁾ ACS880 marine type approval and type approved drives are listed at <https://new.abb.com/drives/segments/marine/marine-type-approvals>.

¹⁷⁾ Marine type approval only available for frames R5i-nxR8i

¹⁸⁾ Three option slots are available for I/O extension, speed feedback, fieldbus and functional safety options.

The slot number for I/O and encoder options can be extended with FEA-03 option.

¹⁹⁾ Three option slots are available for I/O extension, speed feedback, communication protocol and functional safety options.

²³⁾ Three option slots are available for I/O extension, speed feedback, communication protocol and functional safety options.

FSO-xx can also be mounted on a DIN rail by using a separate installation kit. DIN rail mounting does not consume the drive's option slots.

²⁴⁾ Please check availability from your local ABB.

²⁵⁾ Available for R8i

²⁶⁾ For ISU: 500 V, 690 V R7iLC with disconnecter and contactor, 690 V nxR8iLC with air-circuit breaker.

²⁷⁾ Not supported by R7i

²⁸⁾ Not supported by 500 V R7i



—
For more information, please contact
your local ABB representative or visit

new.abb.com/drives/ACS880

new.abb.com/drives

new.abb.com/drives/drivespartners

new.abb.com/motors-generators

Video playlist:
ACS880 how-to videos

